

KVH Industries, Inc.

TracVision® TV3



Installation Guide

PLEASE READ!

Important Addendum to the Installation Guide

New RG-11 Cable Connectors

The Belden Snap N Seal connectors (SNS11AS), used to terminate RG-11 RF cables as described in your antenna installation manual, are no longer available. KVH has validated the PPC Belden-brand EX[®] series 11 universal compression cable connectors as a suitable replacement (see Figure 1).

IMPORTANT!

The EX series 11 universal connectors differ slightly from the Snap N Seal connectors, so it is critical that you follow the installation instructions provided at the manufacturer's website and watch the short video demonstration: <https://www.ppc-online.com/ex-series-7-11-compression-connectors>.

Be sure to adhere to the following steps, in particular:

1. After folding back your cable's braid, align the center conductor with the grooves on the new connector's body. Then mark the cable where it aligns with the base of the connector (see Figure 2).
2. Insert the cable into the connector. Then push firmly, while rotating clockwise, until the connector reaches the mark you made in step 1. The center conductor should protrude from the connector nut.

New RG-11 Compression Tool

Prepare your cables with the tools provided in the RG-11 crimp tool kit (KVH part no. 72-0493) to ensure that the cables are stripped to the correct length for proper engagement between the cable and connector (see Figure 3). Use the Belden CST596711 cable stripper tool (KVH part no. 19-0719) to prepare your cables, then compress the connectors with the new VT200 compression tool (KVH part no. 19-1141-0200) (see Figure 4). When compression is complete, the center conductor should be rigid. If the pin can move in or out, cable performance may be degraded.

Figure 1: New EX Series 11 Connectors for RG-11



KVH Part No. 23-0917

Figure 2: Align the Cable With the Connector

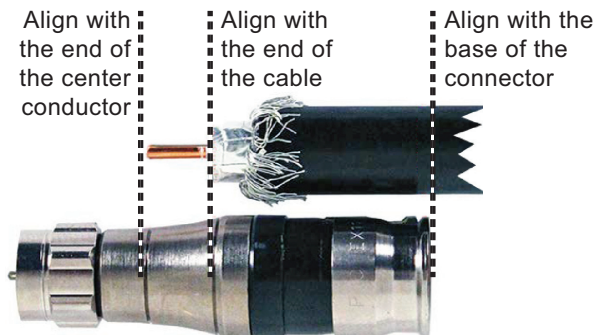

Figure 3: Cable Strip Lengths

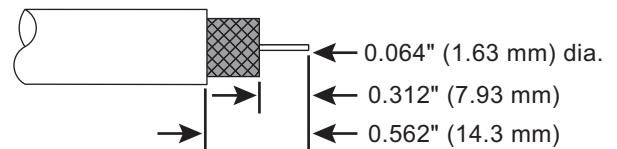

Figure 4: New Compression Tool



TracVision TV3 Installation Guide

This guide explains how to install the TracVision TV3 satellite TV antenna system on a vessel. Operation instructions are provided in the Quick Start Guide.

Installation Steps

- | | | | |
|---|----|--|----|
| 1. Inspect Parts and Get Tools | 3 | 11. Wire the Receivers..... | 13 |
| 2. Plan the Antenna Installation..... | 4 | 12. Connect a NMEA Device | 18 |
| 3. Plan the TV-Hub Installation..... | 5 | 13. Connect Power..... | 19 |
| 4. Prepare the Antenna Site..... | 6 | 14. Turn On the System | 21 |
| 5. Prepare the RF Cables..... | 7 | 15. Access the Web Interface..... | 22 |
| 6. Wire the Antenna | 8 | 16. Connect to an Onboard Network..... | 23 |
| 7. Remove the Shipping Restraint..... | 9 | 17. Secure the Wi-Fi Connection | 24 |
| 8. Mount the Antenna..... | 10 | 18. Set Up the System..... | 25 |
| 9. Mount the TV-Hub..... | 11 | 19. Set the LNB Skew Angle | 28 |
| 10. Wire the Antenna to the TV-Hub..... | 12 | 20. Educate the Customer..... | 29 |

Appendices

- | | | | |
|-------------------------------------|----|--------------------------------------|----|
| A. Installing an IP AutoSwitch..... | 30 | B. Using a DIRECTV Coax Network..... | 33 |
|-------------------------------------|----|--------------------------------------|----|

Who Should Install the System?

To ensure a safe and effective installation, KVH recommends that a KVH-authorized marine technician install the TracVision antenna. KVH-authorized technicians have the tools and electronics expertise necessary to install the system. To find a technician near you, visit www.kvh.com/wheretogetservice.

Technical Support

If you need technical assistance, please contact KVH Technical Support:

Europe, Middle East, Africa, Asia-Pacific

Phone: +45 45 160 180

Email: support@emea.kvh.com

(Mon.-Thu., 8 am-4:30 pm; Fri., 8 am-2 pm, +1 GMT)

North/South America, Australasia

Phone: +1 401 847-3327

Email: support@kvh.com

(Mon.-Fri., 9 am-6 pm; Sat., 9 am-2 pm ET, -5 GMT)

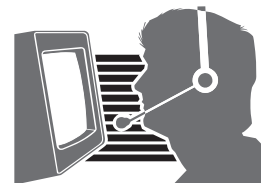

KVH, TracVision, and the unique light-colored dome with dark contrasting baseplate (Reg. No. 2,864,752.) are registered trademarks of KVH Industries, Inc. All other trademarks are property of their respective companies. The information in this document is subject to change without notice. No company shall be liable for errors contained herein.

© 2014-2017 KVH Industries, Inc., All rights reserved. 54-0978 Rev. E

Important Safety Information



This icon indicates a danger, warning, or caution notice. Be sure to read these carefully to avoid injury.



WARNING

Risk of Electric Shock

To avoid electric shock, do not open the TV-Hub chassis enclosure. There are no user-serviceable parts inside.



WARNING

Risk of Electric Shock

If any component of the TracVision system becomes damaged and/or no longer functions normally, disconnect it from vessel power, secure it from unintended operation, and contact KVH Technical Support (see [“Technical Support” on page 1](#)). All repairs or modifications must be performed by a trained, KVH-certified technician. If you are a KVH-certified technician, you still must contact KVH Technical Support prior to conducting any repairs or modifications to the equipment.



WARNING

Risk of Explosion

Do not operate the TV-Hub (or any other electrical device) in an environment where flammable gases, vapors, or dusts are present. In addition, do not operate the TV-Hub in an environment with a temperature outside its 5° F to 131° F (-15° C to 55° C) temperature range.



WARNING

Risk of Electric Shock

Failure to ground the TracVision system properly to ship's ground will cause an unsafe floating ground condition, risking potentially lethal electric shock. See [“Connect Power” on page 19](#) for details on the proper grounding of the equipment.

1 Inspect Parts and Get Tools

Before you begin, follow these steps to ensure you have everything needed to complete the installation.

IMPORTANT!

Always lift the antenna by the baseplate and never by the radome or any portion of the internal antenna assembly (see Figure 1).

- a. Unpack the box and ensure it contains everything shown on the Kitpack Contents List. Save the packaging for future use.
- b. Carefully examine all of the supplied parts to ensure nothing was damaged in shipment.
- c. Gather the tools and materials listed below. You will need these items to complete the installation.
 - Flat-head and Phillips-head screwdrivers
 - Electric drill and 5/16" (8 mm) and 1/8" (3 mm) drill bits
 - 3" (80 mm) hole saw
 - Socket wrenches
 - 7/16" open-end torque wrenches set to 20 in.-lbs (2.25 N-m) and 15 in.-lbs (1.7 N-m)
 - Torque wrench and 2 mm Allen hex key (*linear system only*)
 - Light hammer and center punch
 - Adhesive tape, and scribe or pencil
 - RG-6 or RG-11 RF coax cable(s), with "F" connectors, and termination tools (see [page 7](#))
 - Silicone sealant or equivalent
 - Satellite TV receiver(s)/DVRs for your desired service (see Figure 2)
 - Multimeter
 - Wi-Fi-enabled laptop PC with the latest TracVision software and satellite library downloaded from the KVH Partner Portal (www.kvh.com/partners), or Apple® iOS or Android™ smartphone/tablet with the latest downloads via the TracVision TV/RV mobile app

Figure 1: TracVision TV3 System Components

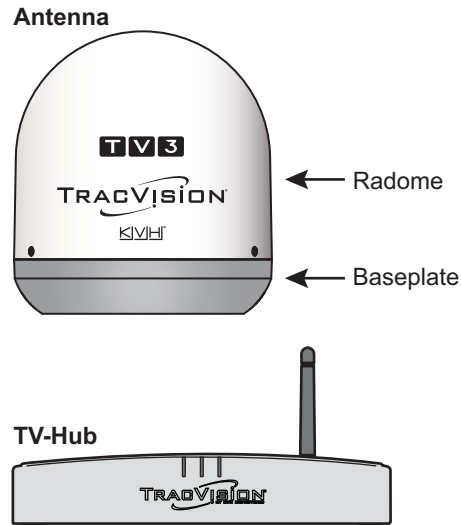

Figure 2: KVH-Validated Receivers

Linear	
For information on the recommended receivers for linear service, contact your local KVH dealer/distributor. Go to www.kvh.com/wheretogetservice to find a dealer/distributor near you.	
DIRECTV*	DISH Network*
H20	311
H21	211
H22	211k
H23	211z
H24	Wally
H25	
HR21, HR21 Pro	Bell TV*
HR22	6100
HR23	6131
HR24	6400

* List is subject to change. For information on connecting different receiver models, contact KVH Technical Support.

2 Plan the Antenna Installation

Before you begin, consider the following antenna installation guidelines.

IMPORTANT!

Be sure to follow the guidelines below. Damage caused by an improper installation is not covered under KVH warranty.

- Minimize blockage. The antenna requires a clear view of the sky to receive satellite TV (see Figure 3). The fewer obstructions, the better the system will perform.
- Consider the distance between your antenna and any radar. KVH requires that you do not mount the antenna on the same level as the radar, because the radar's energy may damage the LNB. Most radar transmitters emit RF energy within an elevation range of -15° to $+15^\circ$ (see Figure 4). Therefore, mount the antenna outside of this elevation range and at least 3 ft (1 m) away from the radar.

IMPORTANT!

Never place the antenna in the beam path of the radar, regardless of distance. The radar's energy may damage the antenna or impair its performance.

- Make sure the mounting surface is wide enough to accommodate the antenna's base (see Figure 5). Also make sure it is flat, level (within $\pm 1^\circ$), strong enough to support the antenna's weight, and rigid enough to prevent antenna vibration.
- Select a location that is as close as possible to the intersection of the vessel's fore-and-aft centerline and midships.
- Be sure to mount the antenna near enough to the TV-Hub to allow you to connect the 50 ft (15 m) coax cable between them, while still maintaining sufficient slack in the cable.

NOTE: If you need a longer cable, use an RG-6 (75 Ω) cable that does not exceed 100 ft (30 m), or an RG11 (75 Ω) cable that does not exceed 200 ft (60 m) (see "Prepare the RF Cables" on page 7).

Figure 3: Blockage from Obstruction

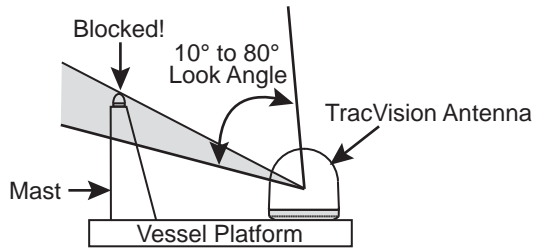

Figure 4: Distance from Radar

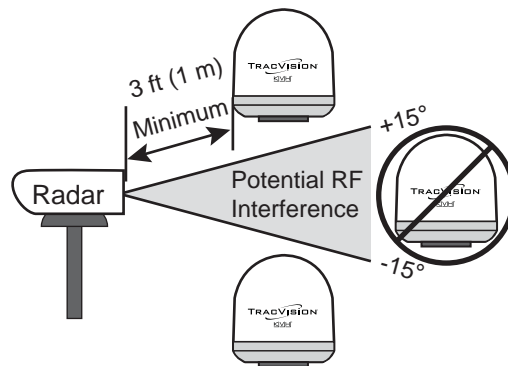
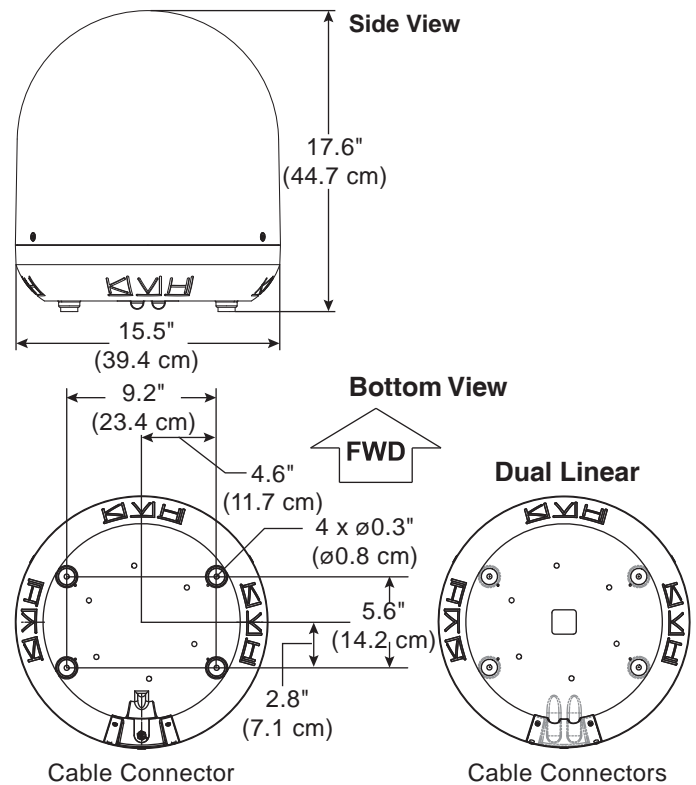

Figure 5: Antenna Dimensions



3 Plan the TV-Hub Installation

Consider the following TV-Hub installation guidelines.

- Select a mounting location in a dry, well-ventilated area belowdecks away from any heat sources or salt spray.
- Do not install the TV-Hub in an area surrounded by metal or near any electrical devices that emit RF noise.
- The TV-Hub can be mounted horizontally or vertically on a flat surface (see Figure 6 and Figure 7).
- Be sure the TV-Hub LED lights will be visible to the user.
- Select a location that will provide adequate clearance for the TV-Hub dimensions (see Figure 6 and Figure 7).
- Leave enough room behind the rear panel (horizontal mount) or below the rear panel (vertical mount) to accommodate connecting the cables and making service loops within the proper bend radius.
- If you plan to use the TV-Hub's Wi-Fi connections, ensure the TV-Hub mounting location provides adequate Wi-Fi reception.
- If you plan to connect the TV-Hub to the vessel's onboard local area network (LAN), choose a location near an available Ethernet port.

NOTE: A template showing the exact locations of the TV-Hub mounting holes and the dimensions between them is provided in the Welcome Kit. Installation details are provided in ["Mount the TV-Hub" on page 11](#).

Figure 6: TV-Hub Dimensions - Horizontal Orientation

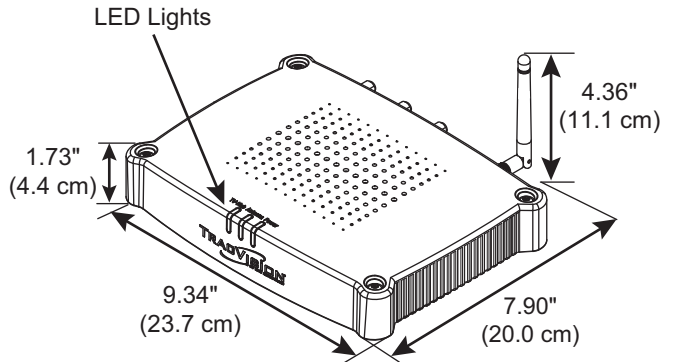
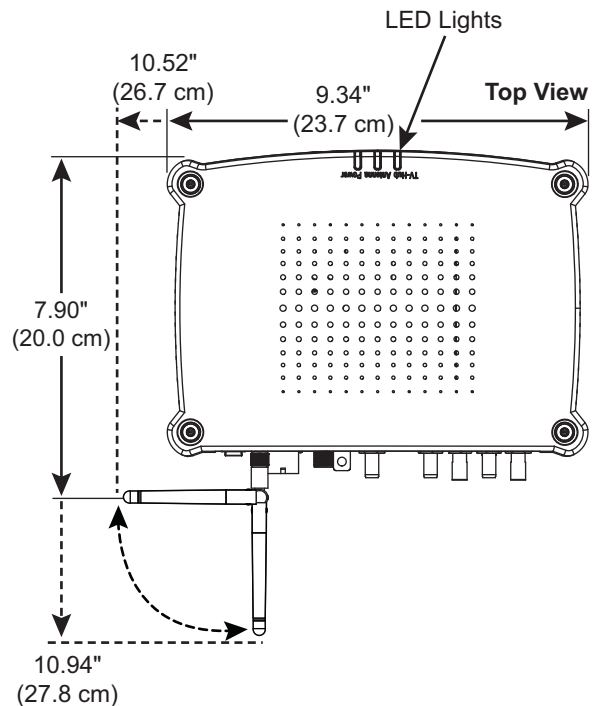

Figure 7: TV-Hub Dimensions - Vertical Orientation



4

Prepare the Antenna Site

Once you have identified a suitable antenna mounting site, according to the guidelines provided on [page 4](#), follow these steps to drill the mounting holes and cable access hole to prepare the site for installation.

- a. Unfold the antenna mounting template (supplied in the Customer Welcome Kit) and place it onto the mounting surface. Make sure the "FWD" (forward) arrow points toward the bow and is **parallel** to the vessel's centerline (see Figure 8). Tape in place.

*NOTE: You don't need to mount the antenna exactly on the vessel's centerline (the closer, the better), but the antenna's forward arrow must be **parallel** to it.*

- b. Using a light hammer and center punch, mark the locations for the four mounting holes and cable access hole on the mounting surface in the locations indicated on the template.
- c. Drill a 5/16" (8 mm) hole at the four mounting hole locations you marked in Step b. Later, you will insert four 1/4"-20 bolts through these holes to secure the antenna to the mounting surface.
- d. Using a hole saw, drill the cable access hole in the location you marked in Step b. Be sure to size the hole approximately to maintain a cable bend radius of at least 3" (75 mm). If the hole location is in the center of the antenna mounting hole pattern, the diameter of the cable access hole must not exceed 3.5" (88 mm). Smooth the edges of the hole to protect the cables. Later, you will route the RF cable(s) through this hole and into the vessel.
- e. Clean and dry the antenna mounting surface.
- f. Peel off the paper backing from the supplied foam seal to expose the adhesive. Then press the foam seal down firmly onto the mounting surface, ensuring the hole in the foam seal aligns with the cable access hole in the mounting surface (see Figure 9).

Figure 8: Antenna Mounting Holes Layout

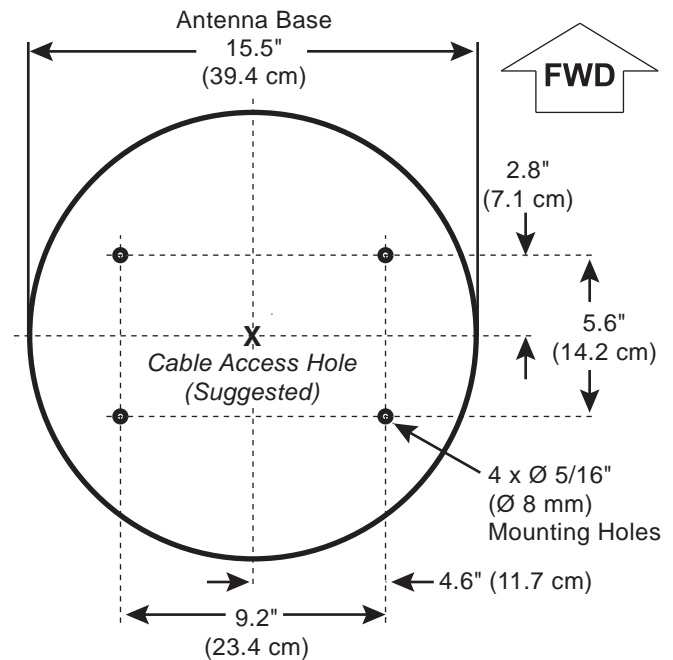

Figure 9: Foam Seal



5 Prepare the RF Cables

Follow these steps to prepare the RF coax cables you will connect to the antenna.

- a. Determine the number of RF cables you need to connect to the antenna for your particular installation (see Figure 10).

NOTE: A system with a dual linear LNB requires an additional 50 ft (15 m) RG-6 RF cable with a sealing boot (KVH part no. 32-0819-50). Spare right-angle connectors and right-angle boot extensions are supplied in the kit.

- b. Determine the type of RF cable(s) and connectors required in addition to what is supplied in the antenna kit (see Figure 11). Then follow the guidelines below to prepare the cable(s).

IMPORTANT!

- Do not reuse old RF cables from a previous antenna installation. The RF1 cable between the TV-Hub and the antenna carries not only satellite signal, but power and data as well. Therefore, the integrity and reliability of this cable is critically important.
- RF cables must be rated for 75Ω, not 50Ω.
- Use of any cables not specified in Figure 11 will void the warranty.
- Low-quality, poorly terminated, or improperly installed RF cables are the most common cause of system problems. Terminate all RF cables with high-quality “F” connectors using the proper stripping/crimping tools, exactly to the manufacturer’s specifications.
- When determining cable lengths, be sure to account for an adequate service loop, approximately 8" (20 cm) at both ends of each cable.

Figure 10: Number of RF Coax Cables to Connect to Antenna

Connecting to:	RF Cables
<i>System with Circular LNB</i>	
1 receiver	1
2 or more receivers	1*
<i>System with Single Linear LNB</i>	
1 receiver	1
<i>System with Dual Linear LNB</i>	
2 receivers	2

* Multiswitch may be required.

Figure 11: RF Cable Requirements

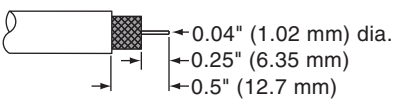
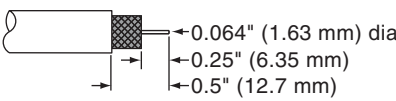
Up to 100 ft (30 m) Cable Run	
Cable	RG-6 (KVH part no. 32-0417-0100)
Connector	Belden SNS1P6 (KVH part no. 23-0170)
Tools	Augat IT1000 (KVH part no. 19-0242)
Strip Lengths	
Up to 200 ft (60 m) Cable Run	
Cable	RG-11 (KVH part no. 32-1272-0200)
Connector	Belden SNS11AS (KVH part no. 23-0213)
Tools	Belden CST596711, L3011B (KVH part no. 72-0493)
Strip Lengths	

Note: LMR-400-75 is a suitable substitute.

6 Wire the Antenna

Follow these steps to connect the RF cable(s).

- a. Using the supplied 3 mm Allen hex key, temporarily remove the connector cover from the antenna's base (see Figure 12).
- b. Route the antenna cable belowdecks through the cable access hole, keeping the end with the rubber sealing boot, shown in Figure 13, at the antenna site. Leave an adequate service loop (8" (20 cm) of slack) in the cable for easy serviceability. *If you are routing the cable underneath the antenna, add a right angle connector and boot extension (see Figure 13).*
- c. Clean and dry the connectors on the RF cable(s) and the antenna (see Figure 14).

	CAUTION
<p>Observe the safe handling instructions in the Material Safety Data Sheet (MSDS) provided with the silicone grease.</p>	

- d. Fill half of the inner body of the RF cable's connector with the supplied silicone grease.
- e. Connect and **SLOWLY** hand-tighten the RF cable to the "RF1" connector on the bottom of the antenna (for a dual linear TV3, see Figure 14), allowing the grease to diffuse and settle into the entire space in the connector.
- f. Make sure the RF cable is hand-tightened all the way into the connector. Then tighten it with a 7/16" torque wrench set to 20 in-lbs, or a 7/16" wrench for 1/4 turn.
- g. Wipe off any excess grease from the outside of the connector.
- h. Mate the boot to the RF connector or boot extension covering the right-angle connector.
- i. If the antenna is a dual linear TV3, label both ends of each cable and repeat steps **b** through **h** to connect the second RF cable to the antenna's "RF2" connector.
- j. Seal the RF cable connections with silicone sealant or equivalent. Then weatherproof and seal the cable access hole as required.
- k. Reinstall the connector cover.

Figure 12: Removing the Connector Cover

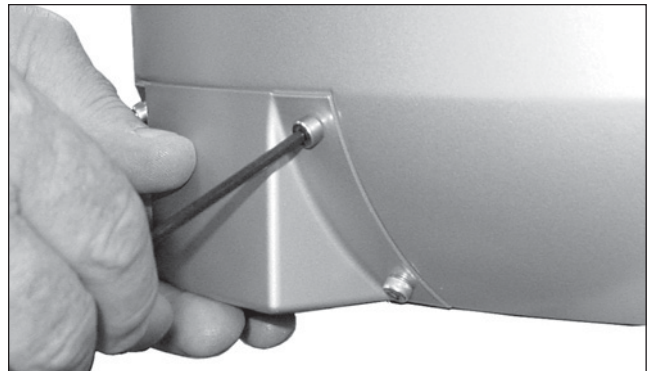

Figure 13: Rubber Boot Extension for Right-Angle Connector

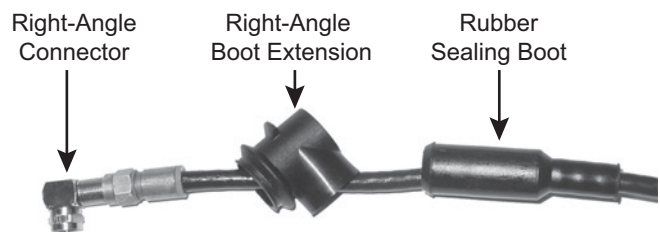
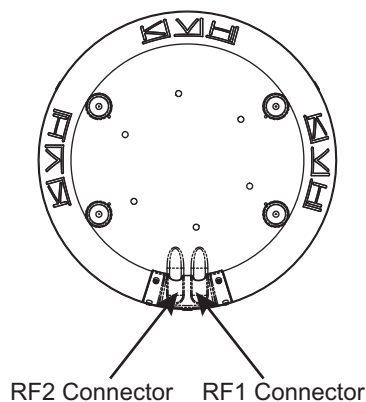

Figure 14: Connectors on Bottom of Dual Linear Antenna



7 Remove the Shipping Restraint

Inside the antenna, a shipping restraint prevents the antenna assembly from moving during shipment. Follow these steps to remove this restraint.

- a. Remove the three #10-32 Phillips screws securing the radome to the baseplate (see Figure 15). Carefully lift the radome straight up until clear of the antenna assembly and set it aside in a safe place.

If you keep the radome topside, secure it with a lanyard to prevent it from falling overboard. Also, do not place the radome on a hot steel deck – the heat may warp the radome.

- b. Using a 10 mm socket wrench, remove the bolt, washer, tag, and spacer securing the antenna assembly to the baseplate (see Figure 16). Save this hardware for future use; the customer will need to reinstall it if he/she needs to relocate or reship the antenna.

IMPORTANT!

Once you have removed the restraint, keep the antenna level as much as possible and handle the antenna very carefully. Prevent the internal antenna assembly from rotating freely within the baseplate to avoid damaging the limit switch.

Figure 15: Removing the Radome

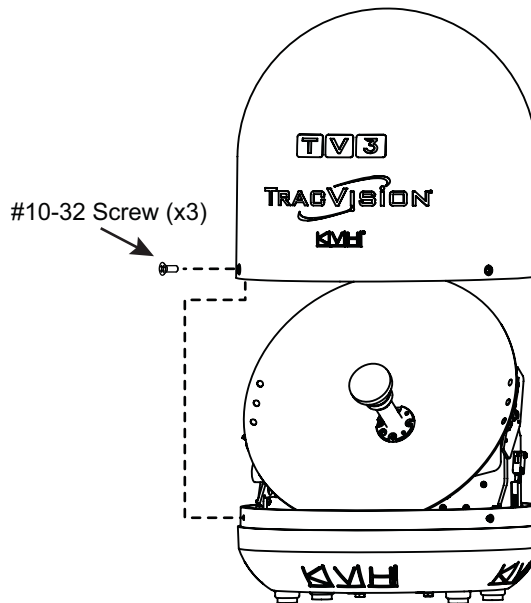
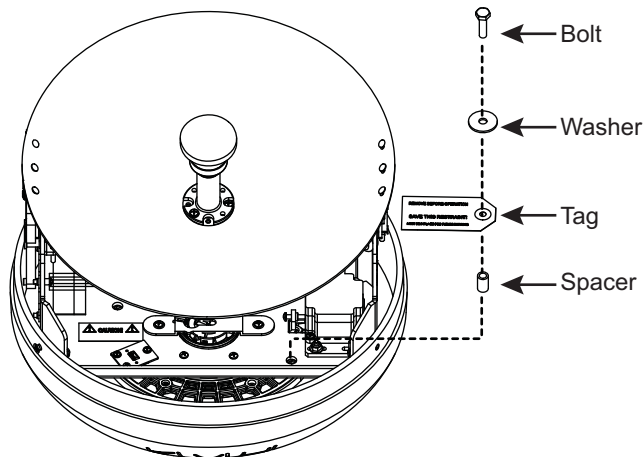

Figure 16: Shipping Restraint Hardware



8 Mount the Antenna

Follow these steps to mount the antenna.

- a. Place the antenna baseplate over the holes drilled in the mounting surface. Ensure the "Forward" arrow inside the baseplate points toward the bow and is **parallel** to the vessel's centerline (see Figure 17).

IMPORTANT!

You will need to rotate the antenna assembly by hand to see all four mounting holes. Rotate it slowly to avoid damaging the limit switch.



CAUTION

Be sure to observe the safe handling instructions in the Material Safety Data Sheet (MSDS) provided with the anti-seize lubricant.

- b. Apply a thin layer of the supplied anti-seize lubricant to the threads of the four 1/4"-20 mounting bolts (see Figure 18).
- c. At each of the four baseplate mounting holes, place a 5/8"-diameter flat washer on a 1/4"-20 bolt and insert the bolt into the hole from above (see Figure 18).
- d. Secure each mounting bolt to the mounting surface using a 1"-diameter flat washer and 1/4"-20 lock nut from below. Tighten all four bolts until the four rubber feet on the baseplate are bottomed against the mounting surface and the foam seal is fully compressed.
- e. Reinstall the radome onto the antenna. Secure in place with the three #10-32 screws you removed on [page 9](#). Hide and protect the screws with the plastic screw caps (supplied in the kit).

Figure 17: Forward Arrow in Antenna Baseplate

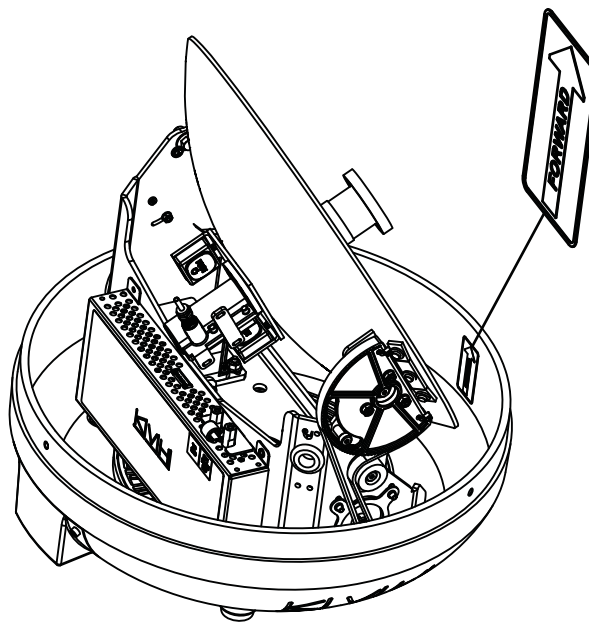
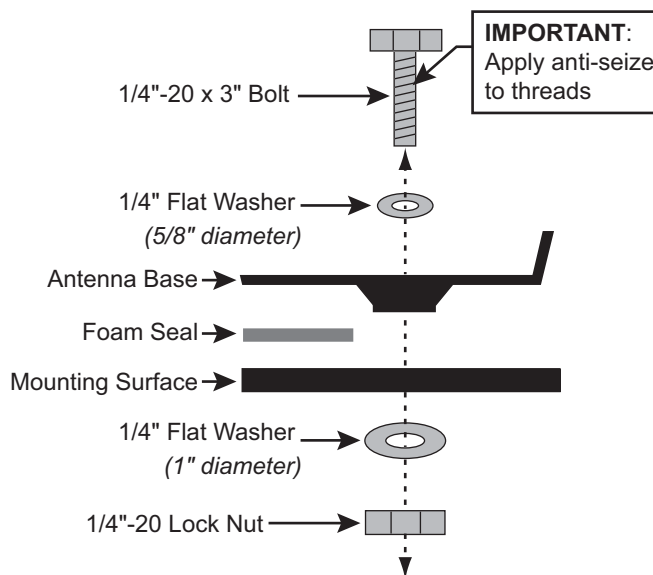

Figure 18: Mounting the Antenna (Side View)



9 Mount the TV-Hub

Follow these steps to install the TV-Hub inside the vessel:

- a. Tape the mounting template in the location selected for the TV-Hub. Punch holes at each of the two keyhole locations and at the mounting tab location.
- b. Remove the template.
- c. Drill a 1/8" (3 mm) hole at the three hole locations you marked in Step a.
- d. Install a #8 Phillips thread-forming screw partway into one of the keyhole holes leaving a small gap for hooking the TV-Hub onto it. Use the thickness (2.5 mm) of the M10 washer supplied in the kit as a gauge for the size gap to leave.
- e. Repeat step d for the other keyhole.
- f. Peel off the backing on the adhesive-backed washer (supplied in the kit) and place it over the mounting tab hole (see Figure 19).
- g. Align the wide part of the TV-Hub's keyholes, as shown in Figure 20, over the screws, then slide downwards to secure the screws into the narrow part of the keyholes.
- h. Press the rear mounting tab of the TV-Hub onto the adhesive washer and install the third #8 Phillips thread-forming screw in the mounting tab hole.

Figure 19: TV-Hub Mounting Template

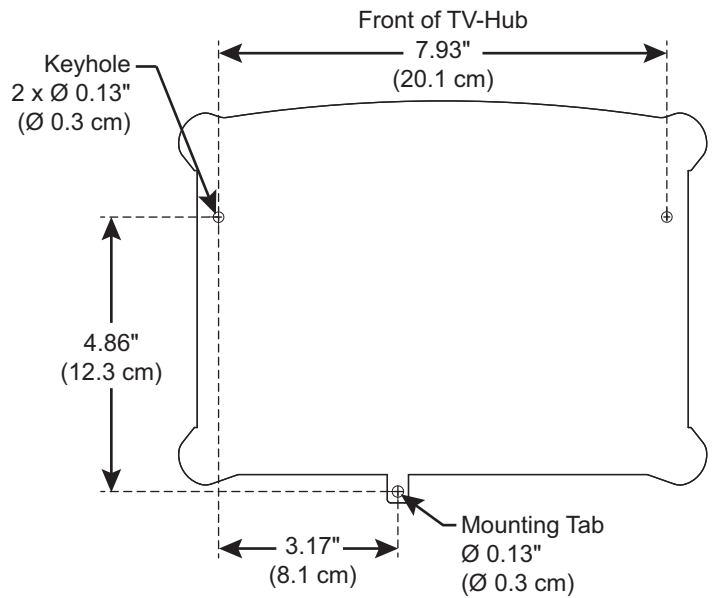
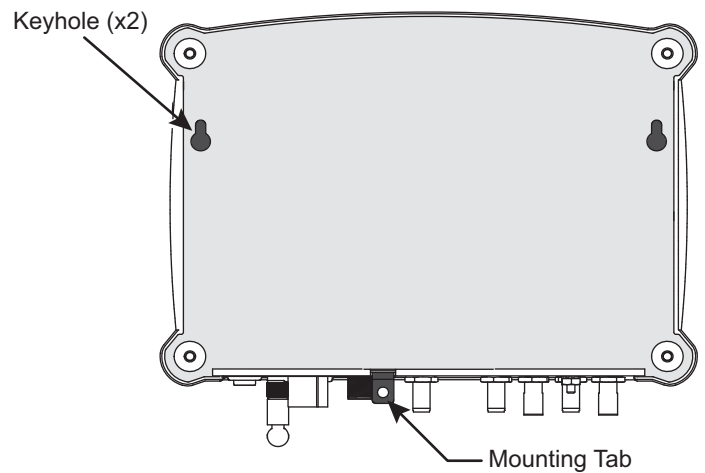

Figure 20: TV-Hub Keyholes and Mounting Tab



10 Wire the Antenna to the TV-Hub

Follow these steps to connect the antenna to the TV-Hub.

- a. Connect the RF1 cable from the antenna to the "Antenna" jack on the TV-Hub (see Figure 21).

IMPORTANT!

Do not connect anything other than the antenna's RF1 cable to the "Antenna" jack. The TV-Hub supplies voltage that will damage other devices, such as multiswitches, receivers, DVRs, etc.

- b. Hand-tighten the RF cable until it is all the way into the "Antenna" jack. Then tighten it with a 7/16" torque wrench set to 15 in-lbs, or a 7/16" wrench 1/8 turn.

Figure 21: TV-Hub Antenna Connection

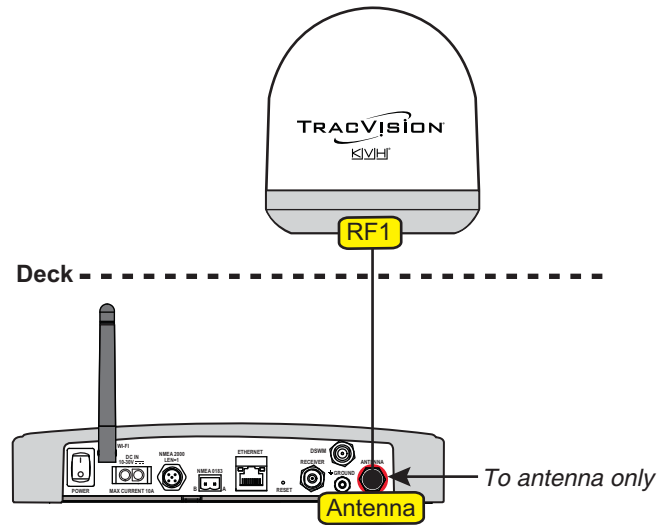

11 Wire the Receivers

The steps for connecting the customer's receiver(s) to the TracVision system and setting them up depends upon the customer's satellite TV service (see Figure 22 and Figure 23).

NOTE: KVH's *TracVision Configuration Wizard*, available at www.kvh.com/tvseriesconfigurator, displays a wiring diagram and parts list for all of the most common configurations.

Follow the steps in the applicable section below to wire the receivers. Then connect the receiver(s) to the customer's television(s).

- Linear..... page 14
- DIRECTV (SWM)..... page 15
- DISH Network/Bell TV page 17

Figure 22: TV-Hub A+ Receiver Connections

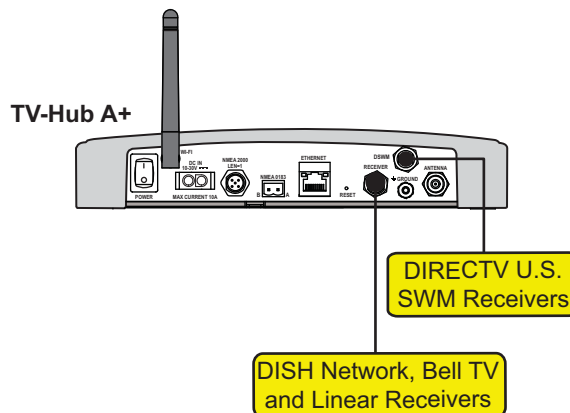
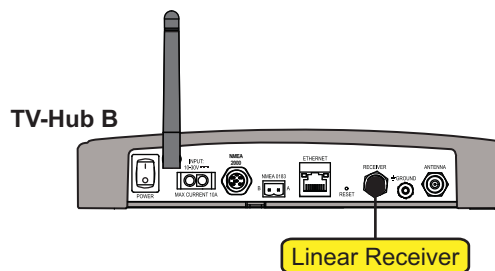

Figure 23: TV-Hub B Receiver Connections



11 Continued Wire the Receivers

Linear Wiring

Follow these steps to connect linear receivers to the TracVision system (*linear universal single LNB or linear universal dual LNB required*).

Connecting 1 Receiver

Connect an RF cable from the “Receiver” jack on the TV-Hub to the “Satellite In” jack on the receiver (see Figure 24). *This receiver will be able to control satellite selection in Automatic satellite switching mode.*

Connecting 2 Receivers (Dual Linear System Only)

- Run a second RF cable (RF2) from the antenna (see “Wire the Antenna” on page 8). Be sure to connect a grounding block in-line with the RF1 and RF2 cables from the antenna (see Figure 25 and “Grounding Requirements” on page 19).
- Connect an RF cable from the “Receiver” jack on the TV-Hub to the “Satellite In” jack on the first receiver. *This receiver will be able to control satellite selection in Automatic satellite switching mode.*
- Connect the RF2 cable from the grounding block to the “Satellite In” jack on the second receiver (see Figure 25).

IMPORTANT!

To enable the second receiver to control satellite selection, install an optional IP AutoSwitch (KVH part no. 72-0634) in-line with the receiver’s RF input. See Appendix A on page 30 for details.

Figure 24: Wiring 1 Linear Receiver

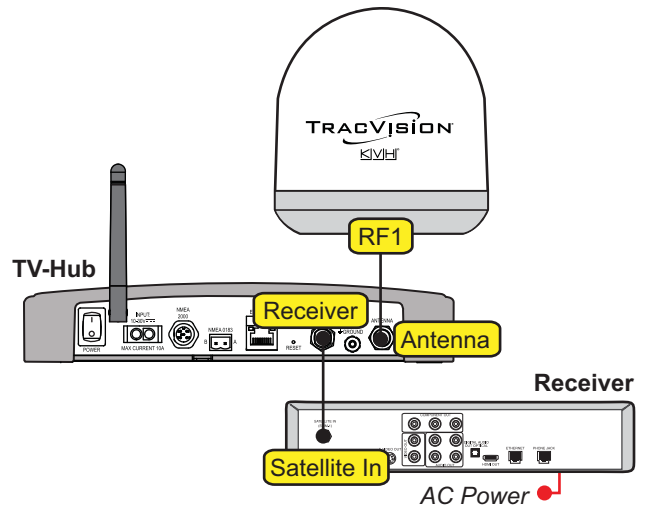
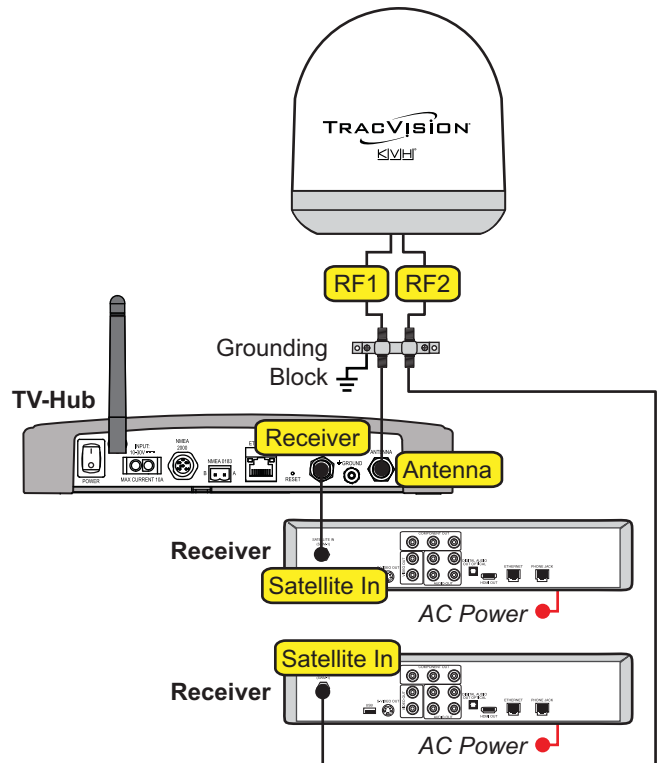

Figure 25: Wiring 2 Linear Receivers (Dual Linear System Only)



11 Continued Wire the Receivers

DIRECTV – SWM Wiring

Follow these steps to connect DIRECTV SWM receivers to the TracVision system (*circular LNB and TV-Hub A+ required*).

Connecting 1 SWM Receiver

Connect an RF cable from the “DSWM” jack on the TV-Hub to the “Satellite In” jack on the receiver/DVR (see Figure 26).

Connecting Up to 8 SWM Receivers (or 13 Tuners)

- Connect an RF cable from the “DSWM” jack on the TV-Hub to the “SWM” input on the SWM splitter (supplied in the kit) (see Figure 27).
- Connect the SWM splitter’s outputs to the “Satellite In” jack on the receivers/DVRs. You can connect up to 8 SWM devices that add up to 13 or fewer tuners. Refer to Figure 27 to determine the tuners consumed by each type of device.
- Terminate any unused outputs on the SWM splitter with the supplied 75Ω terminators and verify all connections are tight.

IMPORTANT!

If you need to receive local channels on the 119W satellite, and you want the antenna to automatically switch between the 101W and 119W satellites, you need to use the DIRECTV coax network. See Appendix B on [page 33](#) for details.

Figure 26: Wiring 1 DIRECTV SWM Receiver

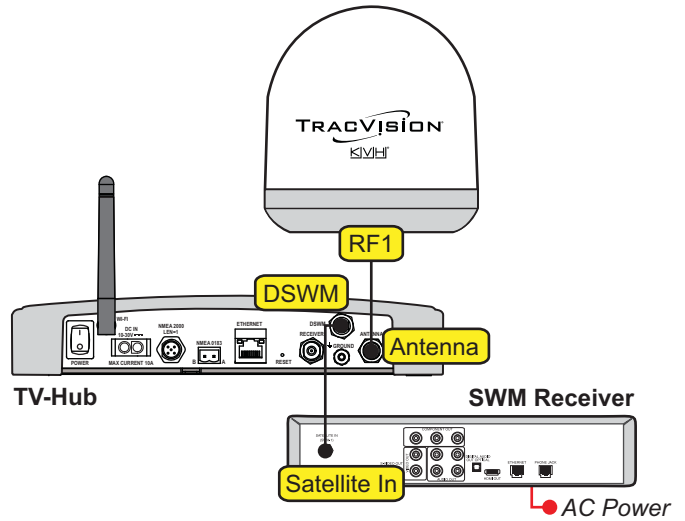
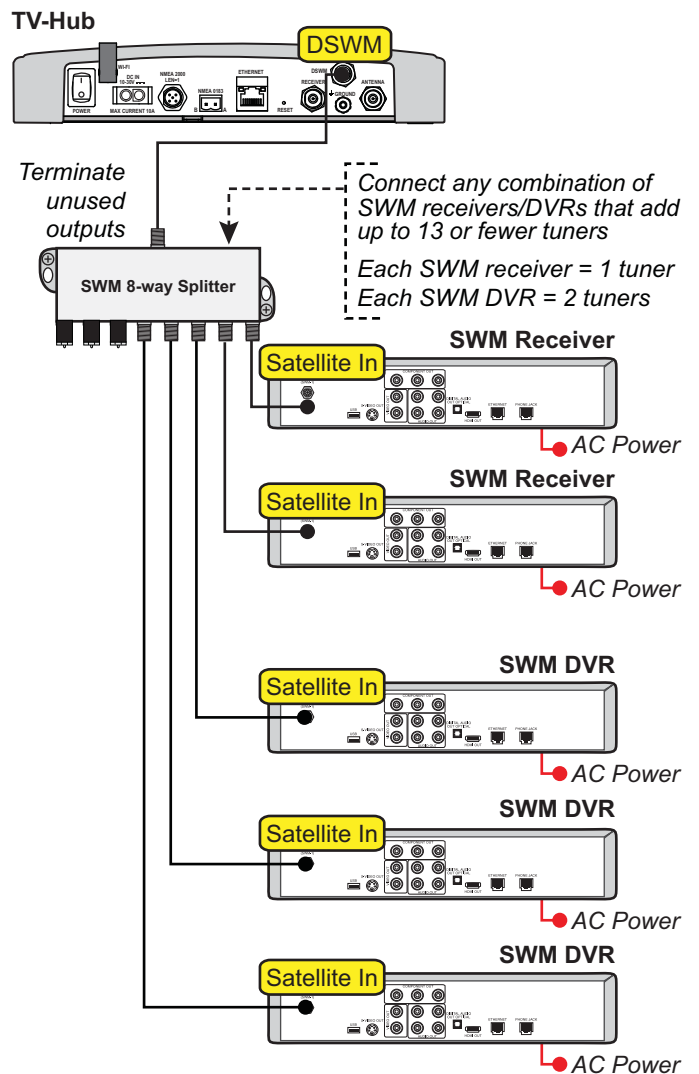

Figure 27: Wiring Up to 8 SWM Devices



11 Continued Wire the Receivers

Connecting 9-13 SWM Receivers (13 Tuners Max)

To connect more than eight SWM devices, connect an RF cable from the “DSWM” jack on the TV-Hub to the “SWM” input on an appropriate splitter (2 and 8-way SWM splitters are available as part of the TV-Hub A+ Expansion Kit (KVH part no. 72-0844)).

IMPORTANT!

When wiring the receivers, be sure to keep the number of splits to no more than two per path.

Install up to three (total) 8-way splitters connecting no more than a total of thirteen tuners. Refer to the wiring example shown in Figure 28.

IMPORTANT!

If you need to receive local channels on the 119W satellite, and you want the antenna to automatically switch between the 101W and 119W satellites, you need to use the DIRECTV coax network. See Appendix B on [page 33](#) for details.

Figure 28: Wiring Up to 13 DIRECTV SWM Devices

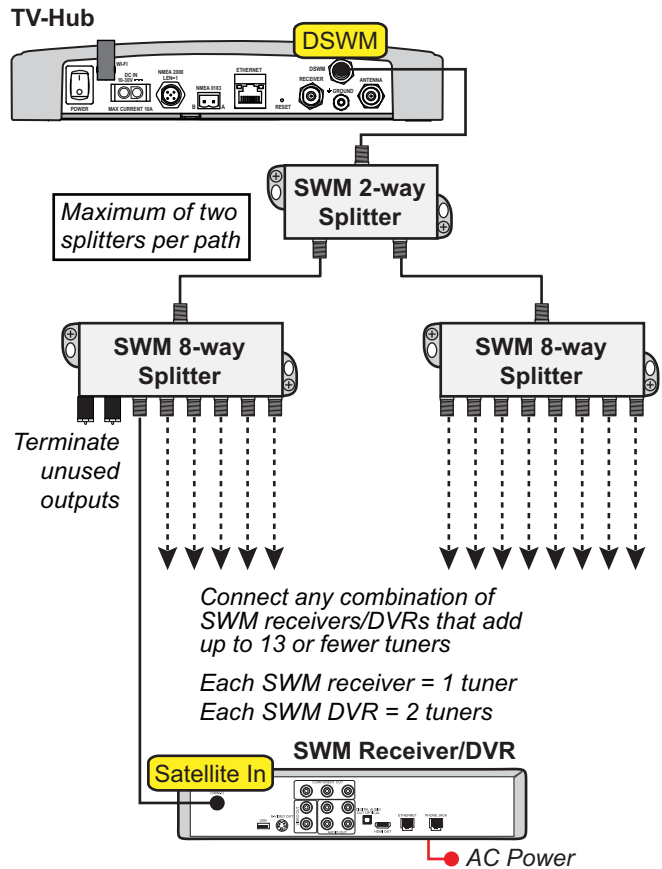

11 Continued Wire the Receivers

DISH Network and Bell TV Wiring

Follow these steps to connect DISH Network or Bell TV receivers to the TracVision system (circular LNB required).

IMPORTANT!

Receivers must be DISH Pro-compatible. Look for the DISH Pro logo on the box.

Connecting 1 Receiver

Connect an RF cable from the "Receiver" jack on the TV-Hub to the "Satellite In" jack on the receiver (see Figure 29).

Connecting 2 or More Receivers

- Connect an RF cable from the "Receiver" jack on the TV-Hub to the "Antenna" jack on the DC block splitter (supplied in the kit).
- Connect the "Primary" jack on the DC block splitter to the "Satellite In" jack on the first receiver. *This receiver will be able to control satellite selection in Automatic satellite switching mode.*
- If you need to connect just a second receiver, connect the "Secondary" jack on the splitter to the "Satellite In" jack on the second receiver (see Figure 30).

If you need to connect three or more receivers, connect the "Secondary" jack on the splitter to the "18V" port on a multiswitch (see Figure 31). KVH offers a 4-output passive multiswitch (KVH part no. 72-0676) and an 8-output active multiswitch (KVH part no. 72-0677).

- When using a multiswitch, connect the multiswitch outputs to the "Satellite In" jacks on the receivers.

IMPORTANT!

To enable any of the additional receivers to control satellite selection in Automatic satellite switching mode, install an optional IP Autoswitch (KVH part no. 72-0634) in-line with its RF input. See Appendix A on [page 30](#) for details.

Figure 29: Wiring 1 DISH/Bell Receiver

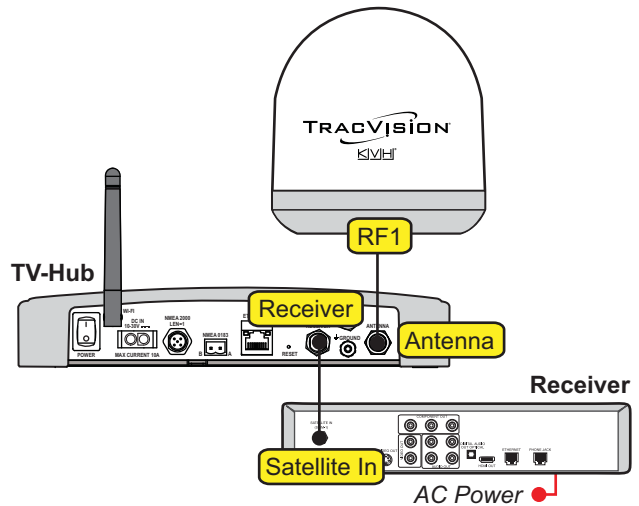

Figure 30: Wiring 2 DISH/Bell Receivers

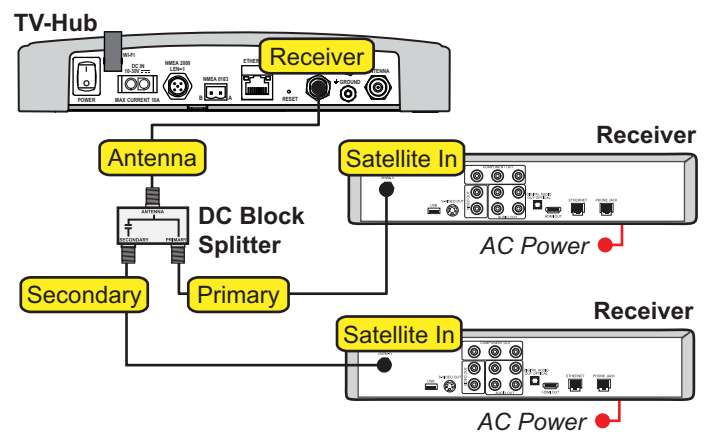
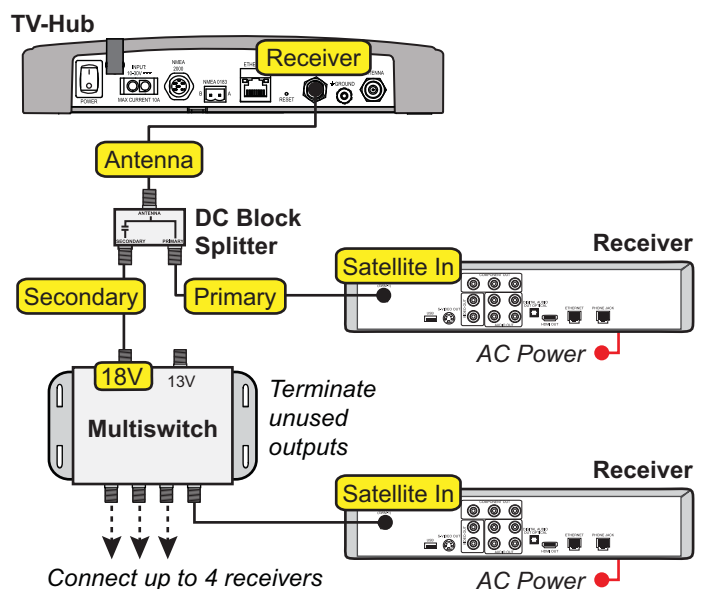

Figure 31: Wiring 3+ DISH/Bell Receivers



12 Connect a NMEA Device

Optional

At the customer's option, you can connect a NMEA device to the TV-Hub, allowing the antenna to use its GNSS position and heading data to speed up satellite acquisition. The current position and heading will also be displayed on the Home page of the web interface.

NOTE: The antenna system can only use and display true heading. If only magnetic heading is input, the TV-Hub will use the current location data to convert magnetic heading to true heading. Without a NMEA GNSS input, the user-entered location will be used.

Follow these steps to connect a NMEA device to the TV-Hub, if desired.

NMEA 0183

- Wire and connect the 2-position terminal strip connector (supplied in the kit) as shown in Figure 32.
- Configure the NMEA device to transmit one or more of the supported NMEA 0183 messages at 4800 baud (see Figure 33).
- Make sure the data message(s) includes the checksum, identifiable by a *xx field at the end of the data sentence (e.g., \$HEHDT,123.4, T*1F). Do not exceed a 10 Hz input rate.

NMEA 2000

- Connect the TV-Hub to the vessel's NMEA 2000 CAN network backbone via a "T" connector, as shown in Figure 32. Be sure to use a standard drop cable: 5-wire (4 conductors + shield) twisted pair with micro-C connectors.
- Configure the NMEA device to transmit one or more of the supported NMEA 2000 messages (see Figure 34).

Later, you will select the NMEA source at the TracVision Setup Wizard (see "Setup Wizard" on page 26).

Figure 32: TV-Hub NMEA Connections

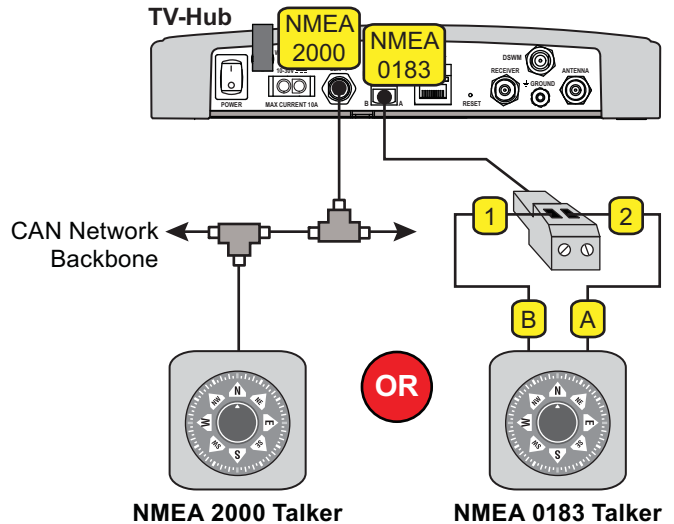

Figure 33: Supported NMEA 0183 Messages

NMEA 0183 \$--xxx	Description
HDG	Heading, Deviation & Variation
HDM	Heading, Magnetic
HDT	Heading, True
OSD	Own Ship Data
THS	True Heading & Status
VHW	Water Speed and Heading
RMC	GNSS Position Data

Figure 34: Supported NMEA 2000 Messages

PGN	Description
127250	Vessel Heading
129029	GNSS Position Data

13 Connect Power

Before connecting power, be sure the vessel is properly grounded in accordance with marine standards.

Grounding Requirements

Proper grounding of the TracVision system to ship's ground is critically important, as it protects the equipment from lightning and electrostatic discharges (ESD). Follow these steps to ground the system.

- Connect the hoop of the grounding wire (supplied in the kit) to the "Ground" screw on the rear panel of the TV-Hub. Connect the other end to ship's ground.
- If two RF cables are connected to the antenna (dual linear system only), connect a grounding block in-line with the RF cables. Attach a ground wire from the grounding block to ship's ground. Then mount the grounding block using the two supplied #6 screws (see Figure 35).

Figure 35: Grounding Block Example

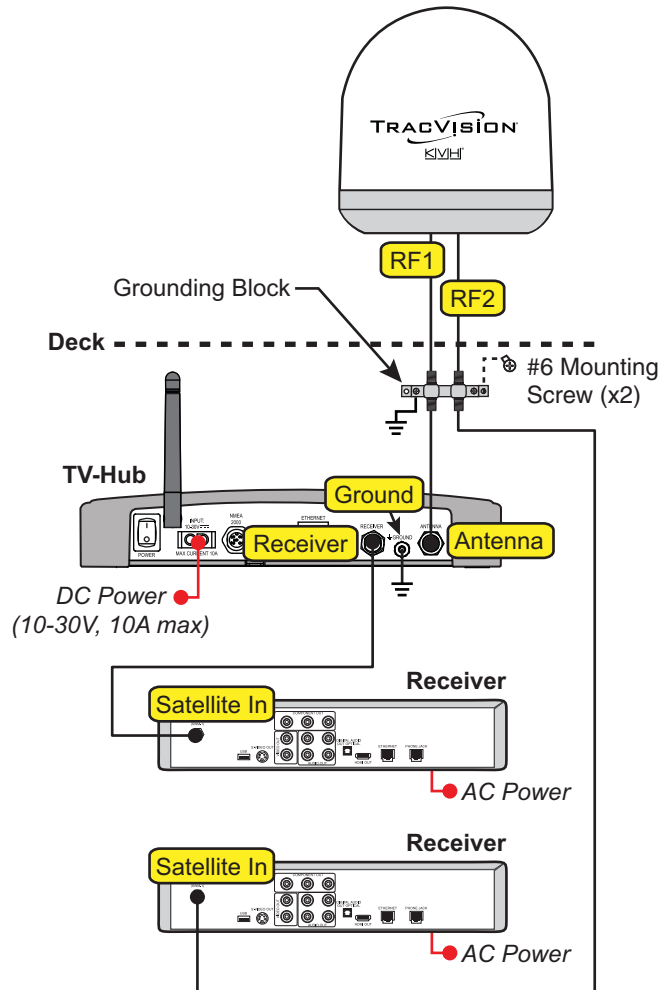

WARNING

Failure to ground the TracVision system properly to the vessel's ground will cause an unsafe floating ground condition, risking damage to the antenna and electric shock, potentially resulting in DEATH. In a floating ground condition, the difference between the equipment's chassis ground and the vessel's ground can measure well over 100 volts, when it normally should not exceed 2 volts. Therefore, always measure the difference in potential between chassis ground and the vessel's ground to make certain that there is no dangerous floating ground condition, even if the ground pin of the vessel's AC power plug appears to be intact.

13 Continued Connect Power

Connect Power to the System

NOTE: When powering up a SWM configuration, apply power to all other system components before powering up the receivers and DVRs (tuners are assigned SWM channels during startup).

Follow these steps to connect power to the TracVision system (see Figure 36).

IMPORTANT!

All power connections must be hard wired.

- Make sure that the ground wire from the TV-Hub has been connected as described on the previous page.
- Connect the TV-Hub power cable (supplied in the kit) to the 10-30 VDC power input on the rear of the TV-Hub.
- Connect the black wire of the TV-Hub power cable to DC return (ship's ground).
- Connect the red wire of the TV-Hub power cable to the vessel's 12 VDC or 24 VDC power source (10-30 VDC is required at the TV-Hub).

NOTE: An optional 24 VDC AC-DC power supply (5 A, 120 W) is available from KVH (part no. 72-0669).

- Check for proper grounding by using a multimeter to measure the AC and DC voltages between the ground stud on the rear of the TV-Hub and ship's ground. The measured voltage should be less than 2 VAC and 2 VDC. **A higher voltage indicates a dangerous floating ground condition.**
- Repeat step e with the TV-Hub powered on, looking for the same measured result.



WARNING

If you measure 2 volts or greater between the ground stud on the rear of the TV-Hub and ship's ground, notify the ship's electrician or authorized vessel representative immediately. This is a dangerous condition. Do not touch the TV-Hub rear panel or connect anything to it until the problem is fixed.

Figure 36: TracVision System Power

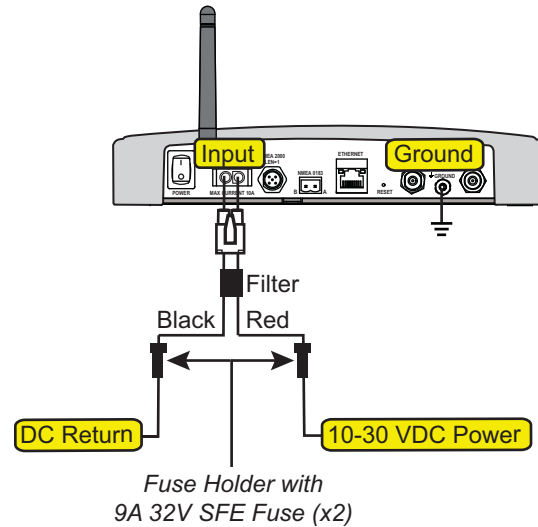

14 Turn On the System

Follow these steps to turn on the system for the first time.

- a. Ensure the antenna has a clear, unobstructed view of the sky.
- b. Press the power switch on the rear panel of the TV-Hub to apply power to the TracVision system (see Figure 37).

IMPORTANT!

During startup, the TV-Hub checks the software versions installed in the antenna and updates them if necessary to match the versions it has stored for that model. All three status lights (see Figure 38) will alternate orange while this update is in progress. **Do not turn off the system during this time.** Updates might take up to 40 minutes.

- c. Within a few minutes, the TV-Hub and Power lights should be lit green (the Antenna light will be flashing green).
- d. Plug in and turn on any connected receivers, DVRs, and televisions.

Figure 37: TV-Hub Power Switch

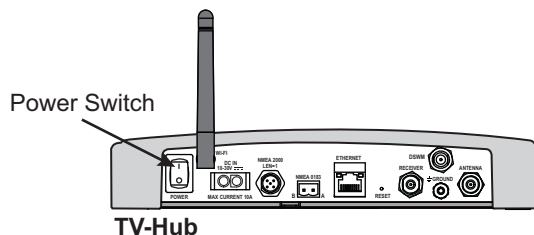
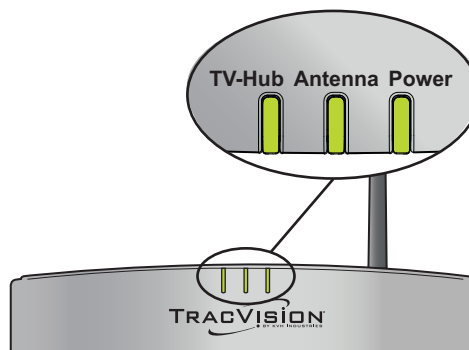

Figure 38: TV-Hub Status Lights



15 Access the Web Interface

Follow these steps to access the TV-Hub's web interface.

Using the Wireless Connection

- a. Select the TVHub-<TV-Hub serial number> network from your device's Wi-Fi settings to connect to the TV-Hub (see Figure 39).
- b. Start your web browser and enter **http://tvhub.kvh**. If the web interface does not appear, try entering **http://172.16.0.1**, which is the default IP address of the TV-Hub.

Using the Ethernet Connection

- a. Connect a laptop PC configured for DHCP directly to the "Ethernet" port on the TV-Hub (see Figure 40).
- b. Start your web browser and enter **http://169.254.253.1**.

NOTE: When connected to a vessel's LAN (see "Connect to an Onboard Network" on page 23), you will need to enter the IP address (dynamic or static) assigned to the TV-Hub. If your laptop has Bonjour[®] installed, you can use it to find the TV-Hub on the network without knowing its IP address.

Figure 39: Wi-Fi Connection

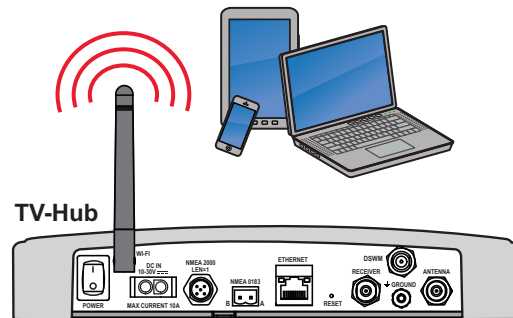
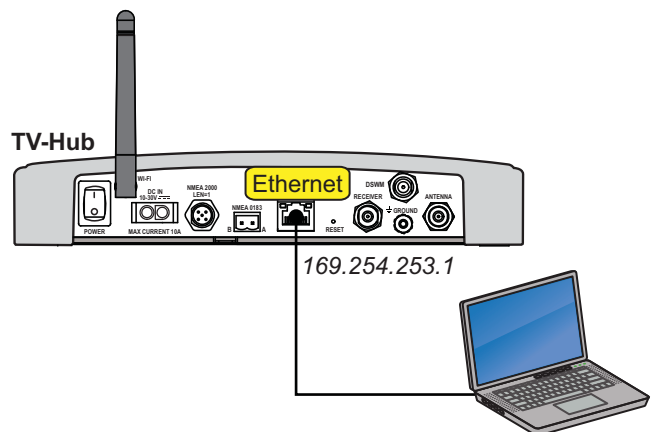

Figure 40: Wired Ethernet Connection



16 Connect to an Onboard Network

Optional

Connecting the TV-Hub to an onboard local area network (LAN) is required if any of the following conditions apply:

- One or more IP AutoSwitches are installed to enable automatic satellite switching (*Linear/DISH Network/Bell TV only*)
- Customer wants to access the TV-Hub’s web interface using any device connected to the onboard network (see Figure 41)

NOTE: Connecting the TV-Hub to the onboard network using its Wi-Fi rather than an Ethernet cable is not recommended because you lose the ability to connect directly to the TV-Hub’s built-in Wi-Fi. You will always need to connect via the network.

NOTE: The Reset button on the rear panel of the TV-Hub (see Figure 42) reverts all network settings back to their original factory settings.

Wired LAN Connection

- Connect the “Ethernet” port on the TV-Hub to the onboard network (LAN) using the supplied Ethernet cable.
- By default, the TV-Hub’s Ethernet port is configured as a DHCP client, and the network’s router automatically assigns it an IP address. However, in this **Dynamic** mode, the TV-Hub could get assigned a different IP address whenever it is turned on.

KVH recommends that you set the TV-Hub to **Static** mode and enter a static IP address at the web interface (see Figure 43) (go to Settings > Network Settings). Be sure to choose a static IP address that is outside the router’s DHCP range (refer to the router’s user manual for details on finding its range.)

IMPORTANT!

For systems with IP AutoSwitch(es), make sure they are on the same local LAN segment as the TV-Hub (see Appendix A on [page 30](#)).

For DIRECTV systems set up for automatic satellite switching, make sure the receiver(s) have IP addresses in the same subnet as the TV-Hub (see Appendix B on [page 33](#)).

Figure 41: TV-Hub Network Connections

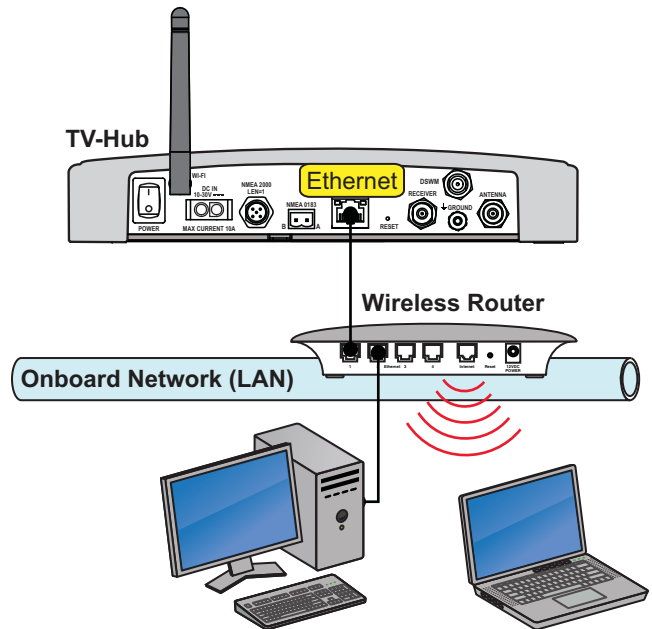

Figure 42: TV-Hub Reset Button

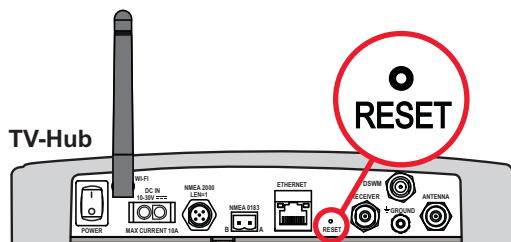

Figure 43: Web Interface Ethernet Settings

Ethernet Settings	
Mode	STATIC
IP Address	192.168.1.200
Subnet	255.255.255.0
Gateway	192.168.1.1
Broadcast	192.168.1.255

17 Secure the Wi-Fi Connection

By default, the TV-Hub's wireless settings are configured for the following:

- Wireless Mode: AP (Access Point)
- SSID: TV-Hub-<TV-Hub serial number>
- IP Address: 172.16.0.1
- Security Mode: Off

KVH strongly advises that you select the **WPA_PSK** security mode as shown in Figure 44 and assign a unique password to prevent unauthorized access to the TV-Hub (at the web interface, go to Settings > Network Settings). If you keep the default settings, you're allowing anyone to access the TV-Hub with their mobile device.

IMPORTANT!

KVH strongly recommends that you keep the TV-Hub set to AP (Access Point) wireless mode. If you select IF (Infrastructure) mode to connect the TV-Hub to your onboard network, you will no longer be able to access the TV-Hub's web interface directly.

Figure 44: TV-Hub Security and Password Setting

Wireless Settings	
Wireless Mode	AP (Access Point) ▼
SSID	TVHub-140311659
IP Address	172.16.0.1
Subnet	255.255.255.0
Gateway	172.16.0.1
Broadcast	172.16.0.1
Security Mode	WPA_PSK ▼
Password	240300659

18 Set Up the System

The Setup Wizard appears upon initial startup to step you through system configuration (see Figure 45). Before you begin to set up the system:

- Know the service provider and associated satellite(s)
- Check the latest software version (see below)
- Verify all system components are connected

Update Software and Satellite Library

Before you start the Setup Wizard, update the system software and satellite library to the latest versions. Use the Apple® iOS or Android™ smartphone/tablet mobile app, or follow these steps to use a laptop PC that has the latest update files downloaded to it from the KVH Partner Portal (www.kvh.com/partners).

- Select **Exit** in the Setup Wizard page. The web interface appears.
- At the Updates page of the web interface, select the antenna model. Then select **Install Update** (see Figure 46). Find the **.kvh** file in your downloads folder, then double-click to install.
- Wait for the update to complete. It may take up to 45 minutes. The TV-Hub's lights will alternate orange while the update is in progress. Once complete, the web interface will report that the latest version is installed.
- When the software update is complete, select the Satellite Library. Then select **Install Update**. Find the **.xml** file in your downloads folder, then double-click to install.
- Close the web interface. Then reopen it (see [“Access the Web Interface” on page 22](#)). The Setup Wizard will reappear since setup has yet to be completed.
- Select **Proceed with Setup Wizard**.

Figure 45: Setup Wizard Welcome Page

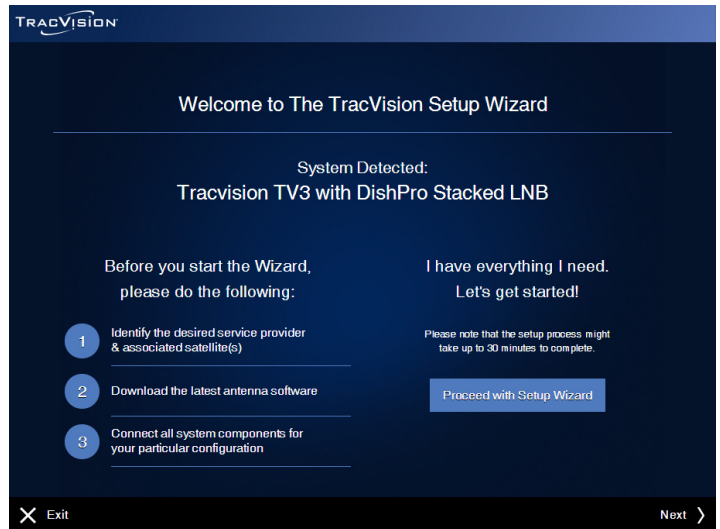
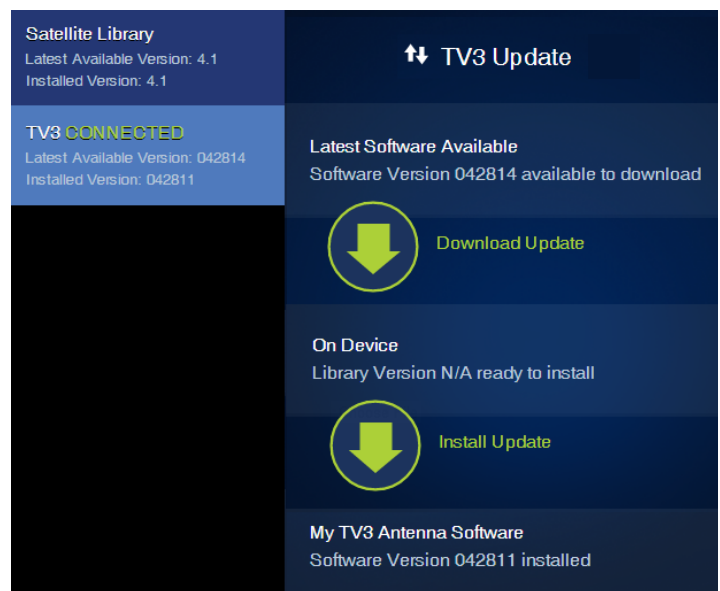

Figure 46: Software Updates Page



18 Continued Set Up the System

Setup Wizard

System configuration continues by prompting you to enter information or perform certain tasks, as necessary. For example:

- Enter installer and vessel information
- Select a source for GNSS position data
- Select a source for heading data (if NMEA device is connected)
- Select the satellite TV service
- Select satellite(s) to track (make your own selections or select one of the preset groups listed in Figure 47), or create user-defined satellites
- Set up automatic switching, if applicable

Additional Setup Information

Once the Setup Wizard has been completed, perform follow-up tasks such as:

- Set up receivers to operate with the system (as instructed by the Wizard)
- Activate the receivers (as instructed by the Wizard)
- Set the antenna's LNB to the skew angle provided by the Wizard (see ["Set the LNB Skew Angle" on page 28](#); applies to linear systems only)

Figure 47: Preset Satellite Groups

Service	Satellites (A-B-C-D)
Linear	Create a custom group if multiple satellites are needed
DIRECTV U.S.	DIRECTV Dual: 101W and 119W
DISH Network	Western Arc: 110W, 119W, 129W Eastern Arc: 61W, 72W, 77W Legacy East Arc: 61W, 110W, 119W DISH 500: 110W, 119W
Bell TV	Bell TV Dual: 82W, 91W

Note: This list is subject to change.

18 Continued Set Up the System

Linear Receiver Setup for Automatic Switching

For automatic switching to work properly using the DiSEqC communications protocol, set up linear receivers for the same satellites installed in the TracVision system. Set up the satellites in the receiver in the exact same order as they were set up in the antenna. The specific setup process varies among receiver models – refer to the receiver’s manual for details. Use the table below and Figure 48 as a guide.

Satellites in Antenna	Matching Satellites in Receiver
Slot A	Port/Switch/LNB/DiSEqC 1 or A
Slot B	Port/Switch/LNB/DiSEqC 2 or B
Slot C	Port/Switch/LNB/DiSEqC 3 or C
Slot D	Port/Switch/LNB/DiSEqC 4 or D

Figure 48: Linear Receiver DiSEqC Settings (Example)

The screenshot displays the TV-Hub Web Interface for Receiver Setup. It is organized into two columns: 'TV-Hub Web Interface' and 'Receiver Setup'. The 'TV-Hub Web Interface' column shows a list of satellite slots (A, B, C, D) with their corresponding satellite names. The 'Receiver Setup' column shows the configuration for each slot, including LNB Type, LNB Power, 22KHz, Toneburst, DiSEqC1.0, DiSEqC1.1, and Motor settings. The DiSEqC1.0 setting is highlighted with a dropdown menu showing 'LNB1', 'LNB2', 'LNB3', and 'LNB4'.

TV-Hub Web Interface	Receiver Setup
Satellite Group Name MyEuropeGroup	Ku_HOTBIRD 6,7A,8 LNB Type 09750/10600 LNB Power 13/18V 22KHz Auto Toneburst None DiSEqC1.0 LNB1 DiSEqC1.1 None Motor None
Slot A Hotbird 6,7,8 Europe - 13E	Ku_ASTRAS 1H,1KR,1L,1M LNB Type 09750/10600 LNB Power 13/18V 22KHz Auto Toneburst None DiSEqC1.0 LNB2 DiSEqC1.1 None Motor None
Slot B Astra 1 - 19E	Ku_ASTRAS 4A LNB Type 09750/10600 LNB Power 13/18V 22KHz Auto Toneburst None DiSEqC1.0 LNB3 DiSEqC1.1 None Motor None
Slot C Astra 4A - 5E	Ku_Eutelsat 7E LNB Type 09750/10600 LNB Power 13/18V 22KHz Auto Toneburst None DiSEqC1.0 LNB4 DiSEqC1.1 None Motor None
Slot D Eutelsat W3A - 7E	

19 Set the LNB Skew Angle

Linear Systems Only

Follow these steps to set the antenna's LNB to the skew angle supplied by the Setup Wizard. A dual linear LNB is shown in this procedure.

- a. At the rear panel of the TV-Hub, set the power switch to the Off position. Verify its Power light goes out.



CAUTION

Disconnect power from the antenna before you remove the radome. The antenna has moving parts that can cause injury.

- b. Remove the antenna's radome as described on [page 9](#).
- c. Locate the LNB on the back of the antenna's reflector (see Figure 49).
- d. Using a 2 mm Allen hex key, loosen the two M4 set screws securing the LNB to the choke feed (see Figure 50).
- e. Adjust the LNB, clockwise or counter-clockwise, until the skew arrow on the LNB points to the correct skew angle you noted when running the Setup Wizard.

IMPORTANT!

Make sure the LNB is fully inserted into the choke feed to ensure optimum performance.

- f. Tighten the two M4 set screws to secure the LNB in place. Apply 11-in-lbs (1.2 N-m) of torque, if possible.
- g. Reinstall the radome.

Figure 49: Location of LNB on Back of Antenna Reflector

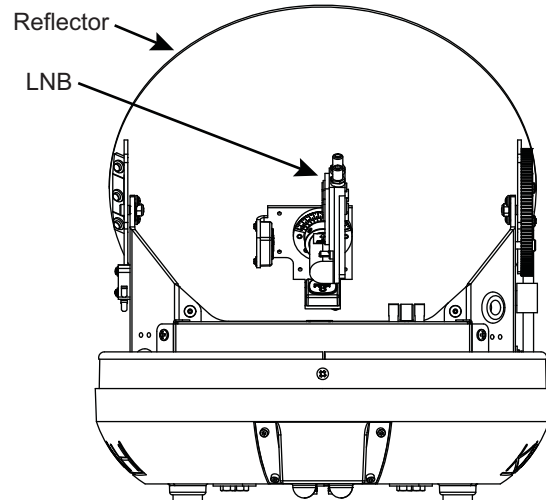
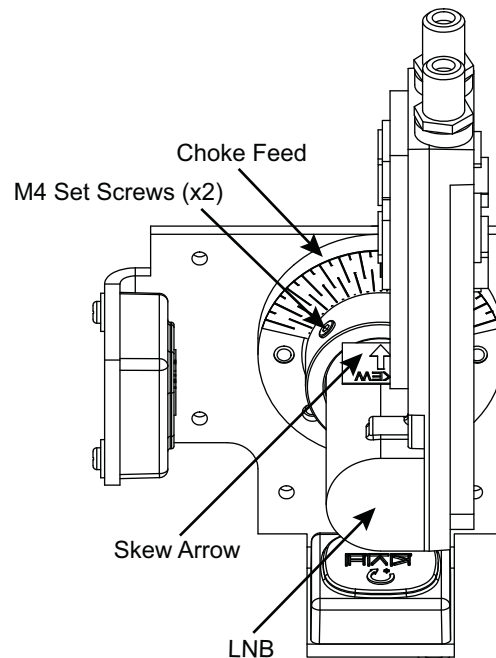

Figure 50: LNB Set Screws and Skew Angle Adjustment



20 Educate the Customer

Before you leave the vessel, test the system to ensure the antenna works properly. Fill out the Installation Checklist (provided in the Welcome Kit) and return it to KVH. Refer to the instructions on the form.

Give the Welcome Kit to the customer, provide any passwords and static IP addresses you set up, and explain how to use the system. Ensure the customer understands the following.

- How to:
 - Turn on the system
 - Access the web interface
 - Switch satellites (see Figure 51)
 - Select a master receiver (see Figure 52)
 - Interpret TV-Hub status information
 - Download software and satellite library updates (using web interface and/or mobile app)
 - Perform general troubleshooting
- Keep the radome installed on the antenna at all times. The radome protects the antenna's moving parts from wind, rain, and debris.

	CAUTION
<p>In the unlikely event that you need to remove the radome, remove power from the antenna first because the antenna's moving parts can cause injury.</p>	

- The antenna must have a clear view of the sky to receive satellite TV. Common causes of blockage include trees, buildings, bridges, and onboard equipment (see Figure 53). Heavy rain or snow might also temporarily interrupt reception.
- Clean the antenna regularly. Dirt buildup on the radome can affect satellite TV reception.
- You must be located within the satellites' coverage area to receive TV signals. Visit www.kvh.com/footprint for coverage maps.
- Please register the system to ensure the best possible service from KVH. Visit www.kvh.com/register for details.

Figure 51: Satellite Switching Selection on Home Page

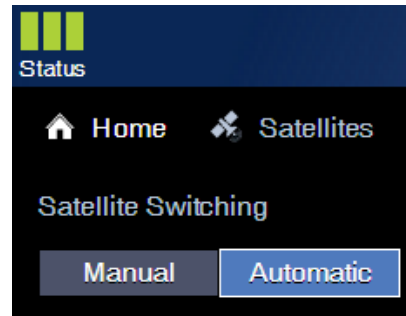
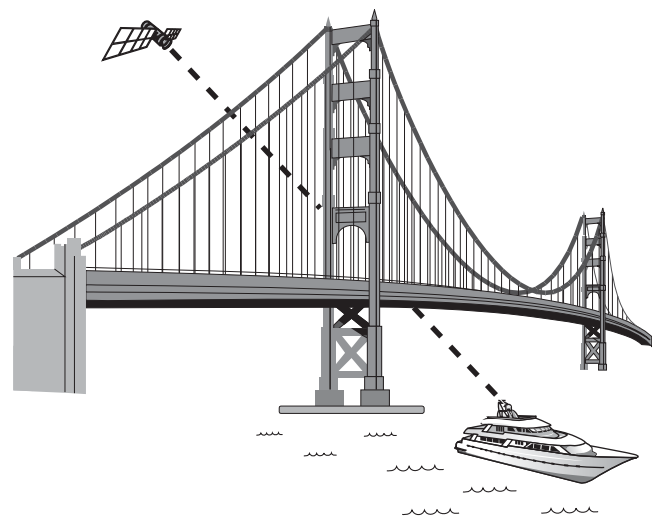

Figure 52: Master Receiver Selection



Figure 53: Blockage Example



A Installing an IP AutoSwitch

Follow these steps to add an IP AutoSwitch (KVH part no. 72-0634) to each DISH Network, Bell TV, or linear receiver you want to be able to control satellite selection in Automatic satellite switching mode.

NOTE: A receiver connected directly to the TV-Hub's "Receiver" jack can control satellite selection without an IP AutoSwitch.

Inspect Parts

Follow these steps to inspect the kit contents.

- a. Unpack the box and ensure it contains each of the following items:
 - 3 ft (1 m) Ethernet cable
 - 2 ft (60 cm) RF cable
 - 1.3 ft (40 cm) RF cable
 - 22 KHz tone blocker
 - Adhesive-backed Velcro strip
- b. Carefully examine all of the supplied parts to ensure nothing was damaged in shipment.
- c. Locate the serial number on the bottom of the IP AutoSwitch (see Figure 55) and record it on the Installation Checklist (supplied in the Welcome Kit) for future reference.

Choose a Mounting Location

Choose a mounting location that meets the following requirements:

- Dry, well-ventilated, and away from heat sources
- Provides a clear view of and easy access to the Master Select button (see Figure 55)
- Provides adequate clearance for running the cables and allows for service loops and strain relief
- Within 2 ft (60 cm) of the associated receiver in order to use the supplied cable
- Either a horizontal or vertical surface

Figure 54: IP AutoSwitch



Figure 55: Serial Number and Master Select Button

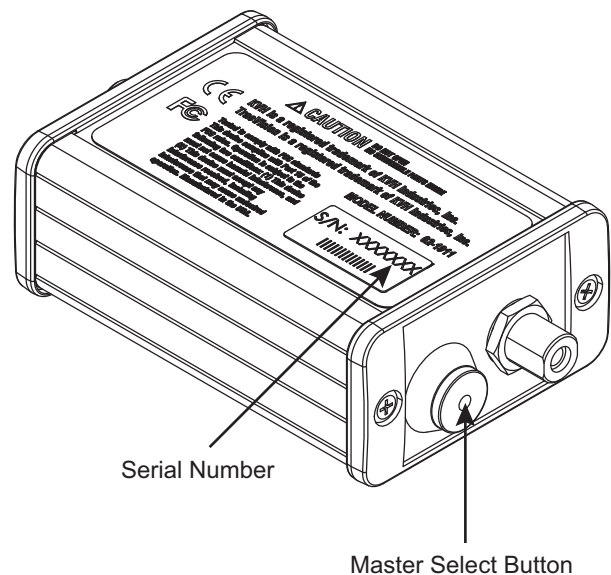

A Continued Installing an IP AutoSwitch

Wire the IP AutoSwitch

The wiring of the IP AutoSwitch depends on the specific configuration. Refer to the wiring diagrams provided in [“Wire the Receivers” on page 13](#), while following the general wiring steps below:

- Disconnect the RF input cable from the receiver and connect it to the “RF In” jack on the IP AutoSwitch. Then tighten to 15 in.-lbs of torque.
- Connect the supplied 2 ft (60 cm) RF cable from the “To Receiver” port on the IP AutoSwitch to the receiver’s satellite input and tighten to 15 in.-lbs of torque.

NOTE: If you are using a 3-input passive multiswitch (e.g., KVH Part No. 72-0676 or 72-0310), install a 22 KHz tone blocker (supplied in kit) inline between the multiswitch and the IP AutoSwitch (see Figure 56).

- Using the supplied Ethernet cable, connect the “Network” port of the IP AutoSwitch to the onboard network. If a network is not available, install a router as shown in Figure 56.
- If not already connected, connect the TV-Hub to the onboard network (see Figure 56).
- Using the supplied Velcro strip, secure the IP AutoSwitch to the mounting surface.

Figure 56: IP AutoSwitch Connections

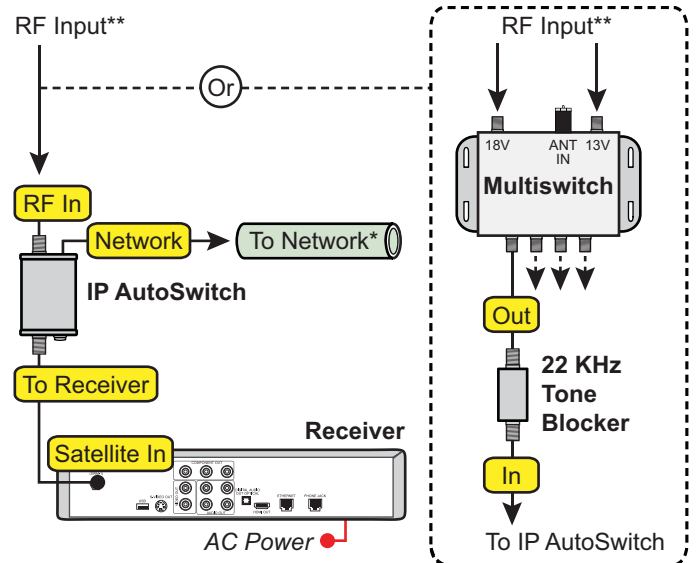

** Varies depending on your system configuration

* Network Connections

Connect the TV-Hub and IP AutoSwitch(es) to your onboard network. If you do not have a network, install a router or router and switch as shown below.

TV-Hub

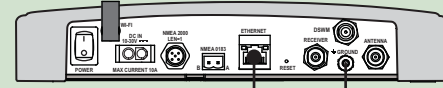

Router

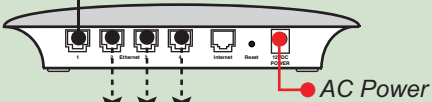

Connect up to 3 IP AutoSwitches

OR



Connect up to 2 IP AutoSwitches

Switch

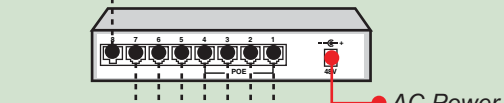

Connect up to 7 IP AutoSwitches

A

Continued Installing an IP AutoSwitch

Configure the IP AutoSwitch

When performing system setup (see “Set Up the System” on page 25), follow these additional steps to configure the IP AutoSwitch.

NOTE: KVH recommends that you run the Setup Wizard in the web interface whenever you change your system’s configuration by adding or removing devices.

- At the AutoSwitch page of the web interface, select **Add IP AutoSwitch** (Figure 57).
- Enter the serial number and choose a friendly name for the IP AutoSwitch (for example, “Salon”).
- Select **Save** to save your changes.

Select the Master Receiver

Any receiver connected to an IP AutoSwitch can become the master receiver for the system. The master receiver controls satellite selection.

IMPORTANT!

The TV-Hub has a built-in IP AutoSwitch. Any receiver connected directly to the TV-Hub can therefore be selected as a master receiver through the web interface.

- To choose the master receiver, select it on the Home page of the web interface, or press the Master Select button on the associated IP AutoSwitch.
- Verify that the LED in the Master Select button on the IP AutoSwitch is lit green (see Figure 58). The LEDs for any other IP AutoSwitches should be lit orange.

Figure 57: Add IP AutoSwitch Screen

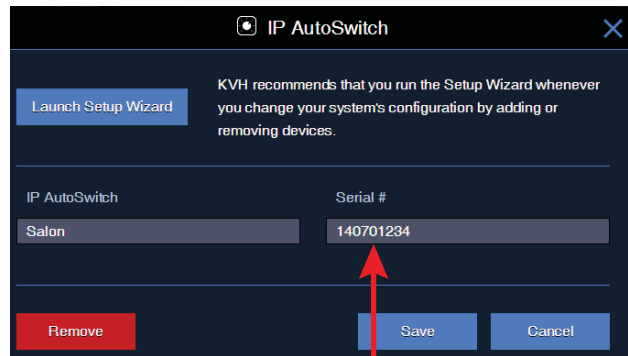

Figure 58: IP AutoSwitch LED Status Indications

LED Color	Indication
Orange	Registered with the system but not currently the master
Orange, flashing	Initializing
Red	Error: <ul style="list-style-type: none"> unable to communicate with the system, network is not detected, or unable to register
Green	Registered with the system and currently the master

B Using a DIRECTV Coax Network

In Automatic satellite switching mode, the TV-Hub can accept commands from the master SWM-compatible DIRECTV receiver to automatically switch between the 101W and 119W satellites. The TV-Hub communicates with the master receiver via the TV-Hub's Ethernet port link to the DIRECTV coax network. Follow the steps in this section to set up this communication link with SWM-compatible receivers

NOTE: The 119W satellite only carries local channels for certain regions of the country. (You can find a list of these regions in the Setup Wizard.) If the customer's locals are carried on DIRECTV's main 101W satellite, there is no need to switch satellites.

DIRECTV Coax Network Connections

DIRECTV uses coax networking technology, by which both satellite TV signals and network communications data are carried by the coax cables. This simplifies installation, since Ethernet cables don't need to be run to all of the receivers.

Install a DECA with power supply and DC to RF adapter, collectively referred to as a DECA Broadband Kit (KVH part no. 19-0860) and formerly called a Cinema Connection Kit. When connected to the SWM splitter and the TV-Hub's Ethernet port, either directly or via an onboard router, the DECA relays messages between the DIRECTV coax network and the Ethernet network (see Figure 59).

Figure 59: DIRECTV Configuration

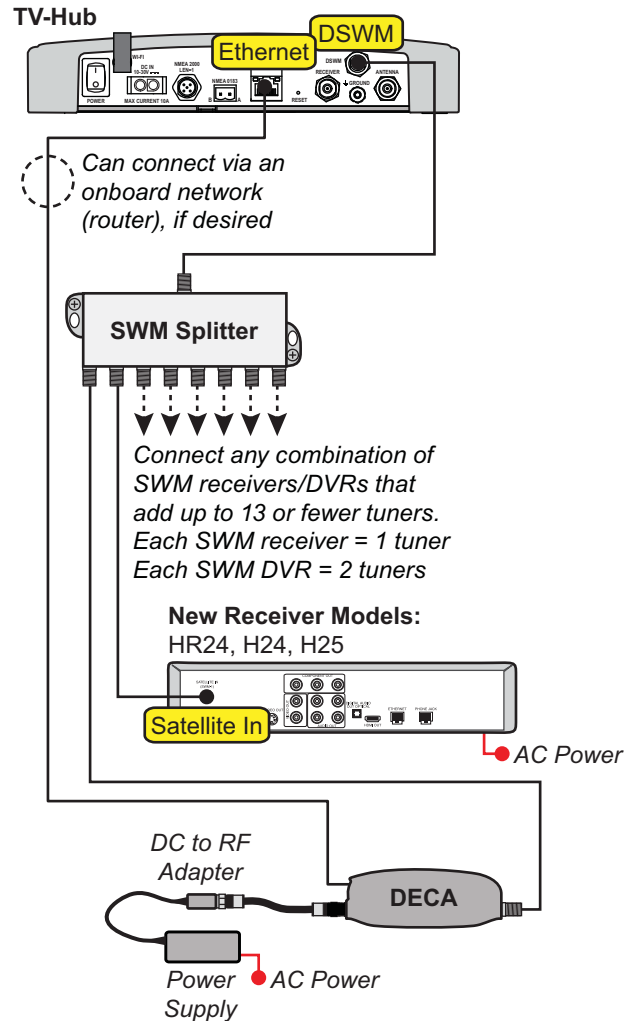

B Continued Using a DIRECTV Coax Network

Additional Equipment for Older Receivers

In addition to the DECA Broadband Kit, you might need to connect an additional device in-line between the receiver and the SWM splitter, depending on the model (see Figure 60).

NOTE: Model HR20-100 requires additional devices not specified here. Contact KVH Technical Support.

H21, H22, H23, HR21, HR22, and HR23

These receivers do not have built-in DECA functionality, but they have an Ethernet port for network connectivity. An additional DECA (KVH part no. 19-0860) is required to support coax networking, supplying the satellite TV signal to the receiver's "Satellite In" port and network communications data to its Ethernet port. (If there are two of each port, use the "Satellite In 1" and "Ethernet 1" ports.)

NOTE: Each DECA you connect directly to a receiver is powered by the receiver. They do not require the separate power supply included in the kit.

H20

This receiver is not network-ready. It is only designed to receive a satellite TV signal via its "Satellite In" port. Since both the satellite TV signal and network communications data are present on the coax cables, a band stop filter (KVH part no. 19-0868) is required to block the network data to prevent potential damage to the receiver. Since the H20 cannot communicate over the network, it cannot control satellite selection.

IMPORTANT!

Be sure to connect all band stop filters before connecting the coax cables.

Figure 60: Additional Equipment for Older Receivers

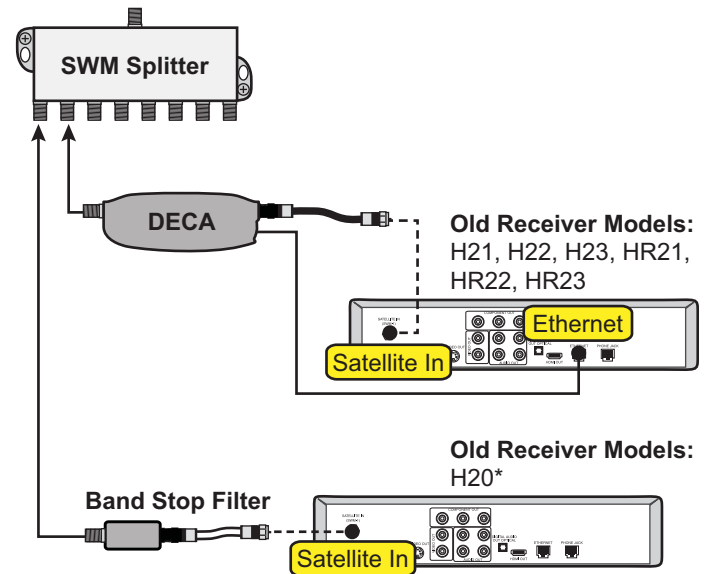

** Model HR20-100 may require additional hardware. Contact KVH Technical Support for details.*

B Continued Using a DIRECTV Coax Network

Configuring the DIRECTV Receivers for Automatic Switching

To establish communications between the TracVision system and each SWM-compatible DIRECTV receiver for automatic satellite switching, you need to set each receiver to a static IP address and enter that address, along with the receiver's location, in the TV-Hub's web interface.

Static IP Address Range WITHOUT an Onboard Network

If the DECA Broadband Kit is connected directly to the TV-Hub's "Ethernet" port (no router is installed), set each receiver's IP address to any address ranging from 192.168.x.2 to 192.168.x.149, where x=1<the last 2 digits in the TV-Hub's serial number>.

For example, if the serial number of the TV-Hub is 140901484, you might assign an IP address of 192.168.184.2 (see Figure 61). Refer to the instructions in ["Assigning Static IP Addresses to DIRECTV Receivers"](#) on page 36. The TV-Hub has a hidden IP address of 192.168.x.1 reserved for automatic switching communications. This IP address is not shown on the Network Settings page of the web interface.

Static IP Address Range WITH an Onboard Network

If the TV-Hub and the DECA Broadband Kit are connected to an onboard network (i.e., router), set each receiver to a static IP address that is outside the router's DHCP range (see Figure 62). (Refer to the router's user manual for details on finding its IP address range.) For example, if the router has an IP address of 192.168.1.1 and assigns IP addresses ranging from 192.168.1.100 to 192.168.1.149 via DHCP, you could set each receiver's IP address to any address ranging from 192.168.1.150 to 192.168.1.254. Refer to the instructions in ["Assigning Static IP Addresses to DIRECTV Receivers"](#) on page 36.

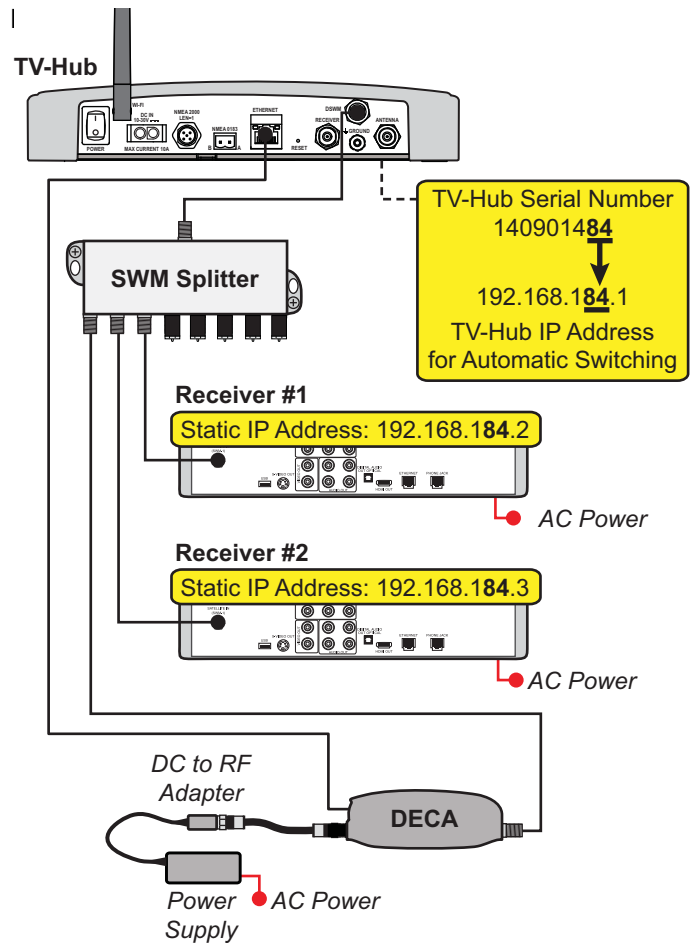

Figure 62: Router DHCP Settings (Example)

IP Address:	192 . 168 . 1 . 1
Subnet Mask:	255.255.255.0
Router Name :	Cisco76205
DHCP Server:	<input checked="" type="radio"/> Enabled <input type="radio"/> Disabled <input type="button" value="DHCP Reser"/>
Start IP Address:	192 . 168 . 1 . 100
Maximum Number of Users:	50
IP Address Range:	192 . 168 . 1 . 100 to 149
Client Lease Time:	0 minutes (0 means one day)

B Continued Using a DIRECTV Coax Network

Assigning Static IP Addresses to DIRECTV Receivers

Once you have identified a valid static IP address range for the receivers, follow these steps to assign a unique static IP address within that range to each receiver.

NOTE: These steps may vary, depending on the receiver's model and software version. Refer to the receiver's owner's manual for details.

- a. Press **MENU** on the receiver's remote control to access the onscreen menu.
- b. At the main menu, highlight **Settings & Help**. Then select **Settings**.
- c. Highlight and select **Network Setup**.
- d. Select **Advanced Setup**.
- e. Change the IP address to the new static IP address (see Figure 63).
- f. **WITHOUT an Onboard Network**
Enter "255.255.255.0" for the subnet mask, and enter the TV-Hub's IP address for default gateway and DNS.

WITH an Onboard Network

Enter the router's subnet mask, and enter the router's IP address for default gateway and DNS.

- g. Highlight and select **Connect Now** to save your changes. Disregard any error messages about missing Internet connectivity. Note this receiver's IP address and location onboard for future reference.
- h. Repeat this procedure for each additional receiver. Be careful not to use the same IP address twice.

Figure 63: IP Address on a DIRECTV Receiver (Example)

WITHOUT an Onboard Network (No Router)

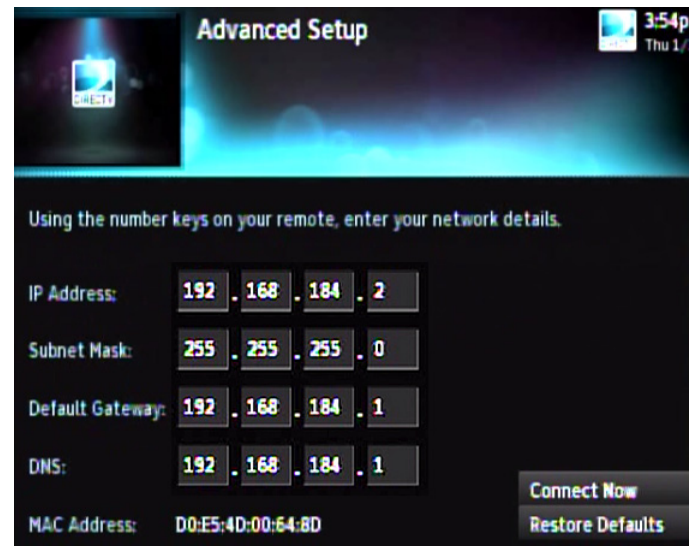

WITH an Onboard Network (Using a Router)



B Continued Using a DIRECTV Coax Network

- i. Add the new receivers to the Autoswitch page of the web interface. Enter each receiver's static IP address and assign it a friendly name (e.g., "Salon") (see Figure 64).

IMPORTANT!

Be sure to enable external device access, as directed by the TV-Hub's Setup Wizard. If the TV-Hub is then unable to communicate with the receiver, try resetting the receiver (press its red reset button or unplug it, wait 15 seconds, then plug it back in and turn it on).

Figure 64: Adding a DIRECTV Receiver to the Autoswitch Page

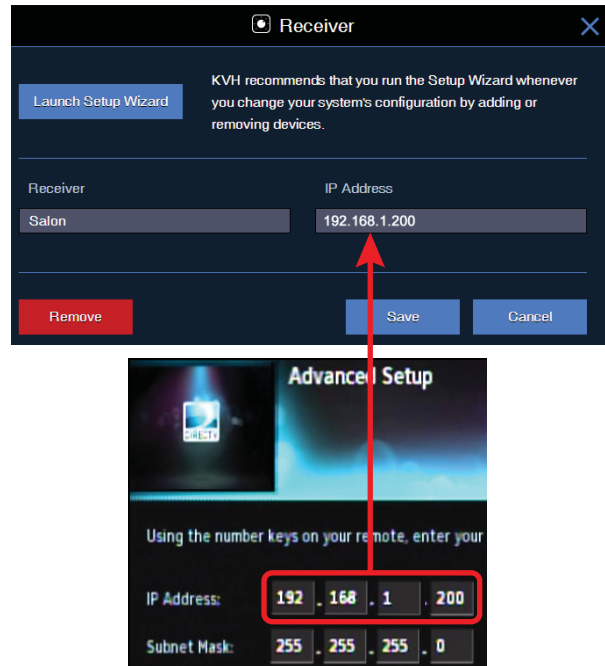



CE Declaration of Conformity

The undersigned of this letter declares that the following equipment complies with specified harmonized standards of EC Directives 2006/95/EC and 2004/108/EC.

Equipment included in this declaration

KVH TracVision® Satellite Television Systems, (Including All Variants)

PRODUCT DESCRIPTION
TracVision TV1 With IP Enabled TV-Hub
TracVision RV1 With IP Enabled TV-Hub
TracVision TV3 With IP Enabled TV-Hub
TracVision TV5 With IP Enabled TV-Hub
TracVision TV6 With IP Enabled TV-Hub
TracVision TV8 With IP Enabled TV-Hub

Declaration and Certification

The TracVision system complies with the following harmonized standards

REQUIREMENT	APPLIED STANDARD
Low Voltage Directive (Health and Safety)	EN 60950-1:2006/AC:2011
EMC:	EN60945:2002 + Corrigendum 1:2008
Conducted Emissions	EN 60945:2002 Section 9.2
Radiated Emissions	EN 60945:2002 Section 9.3
Immunity to Conducted Radio Frequencies	EN 60945:2002 Section 10.3
Immunity to Radiated Radio Frequencies	EN 60945:2002 Section 10.4
Immunity to Fast Transients	EN 60945:2002 Section 10.5
Immunity to power supply short term variations	EN 60945:2002 Section 10.7
Immunity to power supply failure	EN 60945:2002 Section 10.8
Immunity to electrostatic discharge	EN 60945:2002 Section 10.9

Manufacturer

KVH Industries, Inc.
50 Enterprise Center
Middletown, RI 02842-5279
USA

Rick Jones, Director of Corporate Quality

Date



www.kvh.com



KVH Industries A/S
EMEA Headquarters
Kokkedal, Denmark
Tel: +45 45 160 180 Fax: +45 45 160 181
Email: info@emea.kvh.com

KVH Industries, Inc.
World Headquarters
Middletown, RI U.S.A.
Tel: +1 401 847 3327 Fax: +1 401 849 0045
Email: info@kvh.com

KVH Industries Pte Ltd.
Asia-Pacific Headquarters
Singapore
Tel: +65 6513 0290 Fax: +65 6472 3469
Email: info@apac.kvh.com